

HumidiClean™ Humidifiers Series HC- 6100/6300/6500/6700

Installation, Operation and Maintenance Instructions



Please read and save
these instructions

Contents

Warning Labels	3-4
Model Number Description	5
Installation	6-13
Display Menus	14-15
Start-Up Procedure and Operation	16
Maintenance	17-21
Troubleshooting	21-26
Typical Wiring Schematic	27-36
Repair Parts	37-41
PID Control	42
Software Update	43-45
Communication	46-55
Dimensional Data	56-57
Start-Up Checklist	58-59
Start-Up Procedure	60
Warranty	63

Warning Labels

The Armstrong HumidiClean™ humidifier converts ordinary tap water or purified water to steam for distribution to raise the relative humidity level.

To allow HumidiClean™ to function to its full capability, be certain to install in accordance with Armstrong recommendations.

DANGER: ELECTRICAL SHOCK HAZARD HIGH VOLTAGES EXIST INSIDE THE HUMIDIFIER

TO PROTECT YOURSELF AND OTHERS FROM ACCIDENTAL SHOCKS:

1. Keep the humidifier locked during normal operation and store the key in a safe location away from the humidifier.
2. **ALWAYS DISCONNECT THE POWER SUPPLY AT THE CIRCUIT BREAKER OR SAFETY SWITCH BEFORE OPENING ANY COVERS AND DOORS!**
3. Before servicing the humidifier, learn where the high voltage parts are. **KEEP HANDS AND METAL TOOLS AWAY FROM THESE AREAS!**

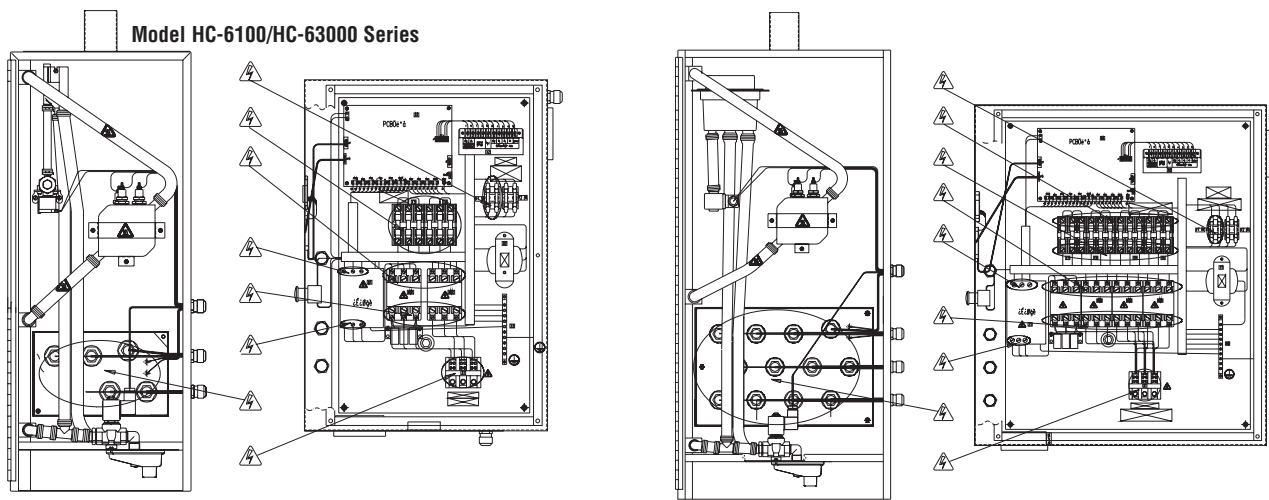

6010-ISO Electrical Shock-Electrocution

Warning: All wiring and installation must be completed by qualified personnel only and per the relevant local or national codes on electrical wiring. Negligence of this warning might result in the loss of property or personal damage.



6043-ISO Burn Hazard Hot Surface

Warning: High Temperature! Material that is not resistant to high temperature should not come in contact with these areas. Negligence of this warning might result in the loss of property or personal damage.



Warning: Do not operate the supplied humidifier in combustible or explosive surroundings.



Warning: Do not operate the supplied humidifier if there is any damage to the cabinet or any components in humidifier are damaged.



Warning: The main switch should be a connection breaker which has over current and leakage current protecting functions per code EN60947-3 or EN60947-2 if point gap required by EN60947-3 can be fulfilled.

4. Physical environment and operating conditions

- Ambient temperature + 4°C ~ + 38°C (40°F to 100°F)
- Humidity = 50 % at 40°C (104°F), = 90 % at 20°C (68°F)
- Altitude = 1000 m (above mean sea level) (3300 ft)

5. Transportation and storage conditions

Electrical equipment shall be designed to withstand, or suitable precautions shall be taken to protect against, the effects of transportation and storage temperatures within a range of -25°C to + 55°C (-15°F to 130°F) and for short periods not exceeding 24h, up to +70°C (160°F). Suitable means shall be provided to prevent damage from humidity, vibration and shock.

6. Requirements

The supply disconnecting device (i.e. a switch-disconnect, a disconnect used in combination with switching devices, or a circuit-breaker) shall fulfill all of the following requirements:

- Isolate the electrical equipment from the supply and have one OFF (isolated) and one ON position only, clearly marked with “O” and “I” (symbols 60417-2-IEC-5008 and 60417-2-IEC-5007, see 10.2.2), with the actuating directions in accordance with IEC60447. Circuit-breaker that, in addition, has a reset (tripped) position between “O” and “I” are also deemed to satisfy this requirement.
- Have a visible gap or a position indicator which cannot indicate OFF (isolated) until all contacts are actually open and there is an adequate isolating distance between all the contacts in accordance with IEC 60947-3.
- Be provided with a means permitting it to be locked in the OFF (isolated) position (e.g. by padlocks). When locked, remote as well as local closing shall be prevented.
- Disconnect all live conductors of its power supply circuit. However, for TN supply systems, the neutral conductor may or may not be disconnected. It is noted that in some countries, disconnection of the neutral conductor (when used) is compulsory.
- The handle of the supply-disconnecting switch shall be located between 0.6m and 1.7m (2 ft. and 5-1/2 ft) above the servicing level.
- The disconnecting switch must have over current and overload protecting functions and initialize them as low as possible under normal running.
- The disconnecting switch should have a breaking capacity sufficient to interrupt the largest normal running current of loads. The breaking capacity required should be selected according to the table on page 8.

Model Number Description

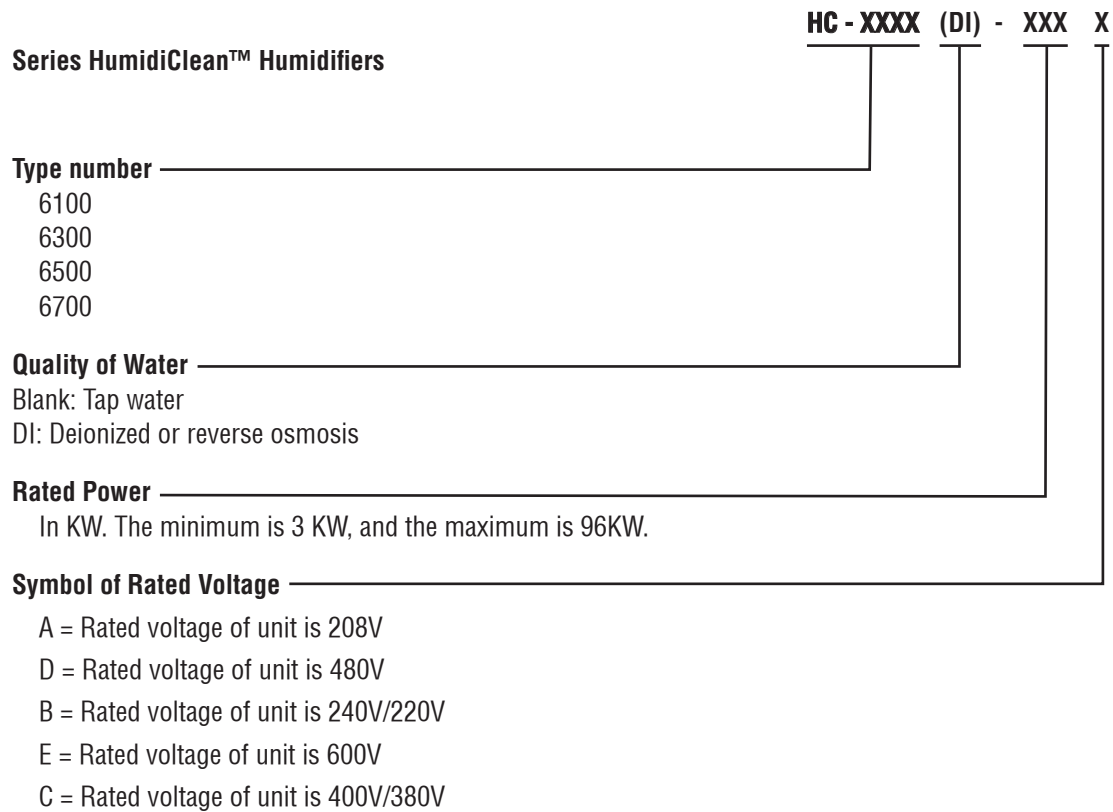

Pre-Installation

1. **Check Shipment.** A claim should be filed with the transportation company, (and reported to Armstrong), if any items are missing or damaged.
2. **Check Local Codes.** The installation of HumidiClean™ should be in accordance with all applicable building, plumbing, and electrical codes.
3. **Site Selection.** The humidifier should be installed in an easily accessible location. **Do not install the unit where malfunction of the humidifier might cause damage to non-repairable, irreplaceable or priceless property.** Refer to Installation section for other details regarding site selection.

Installation

Figure 6-1 HC-6100/6300 Installation

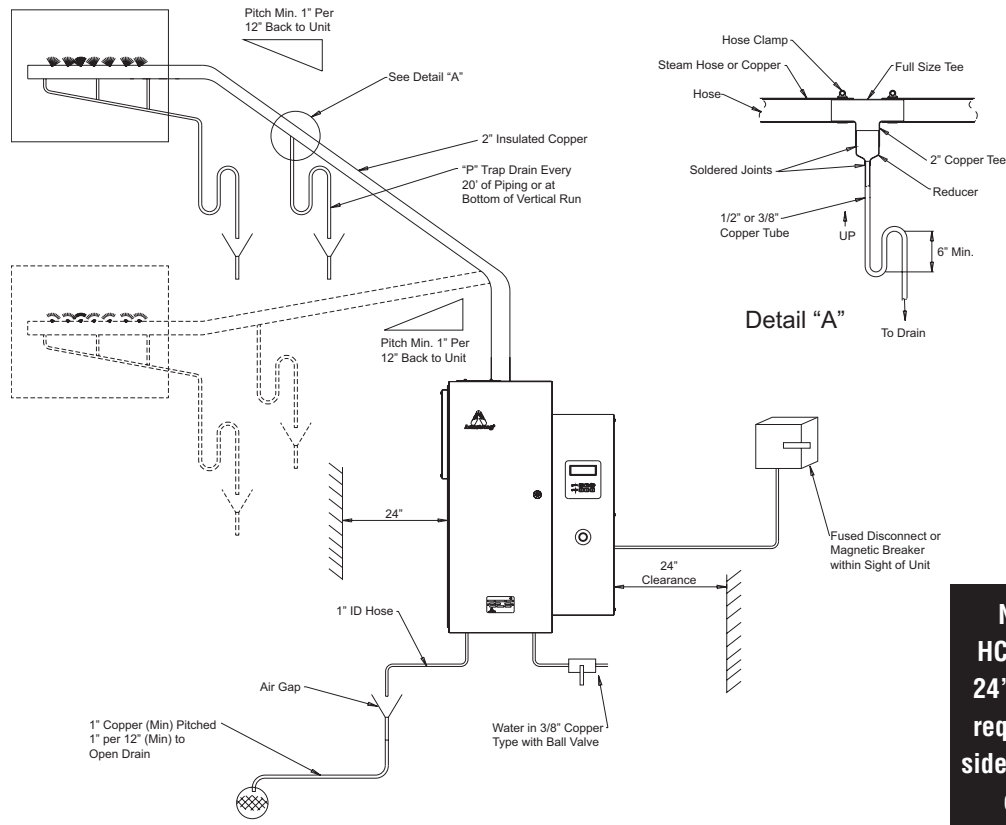
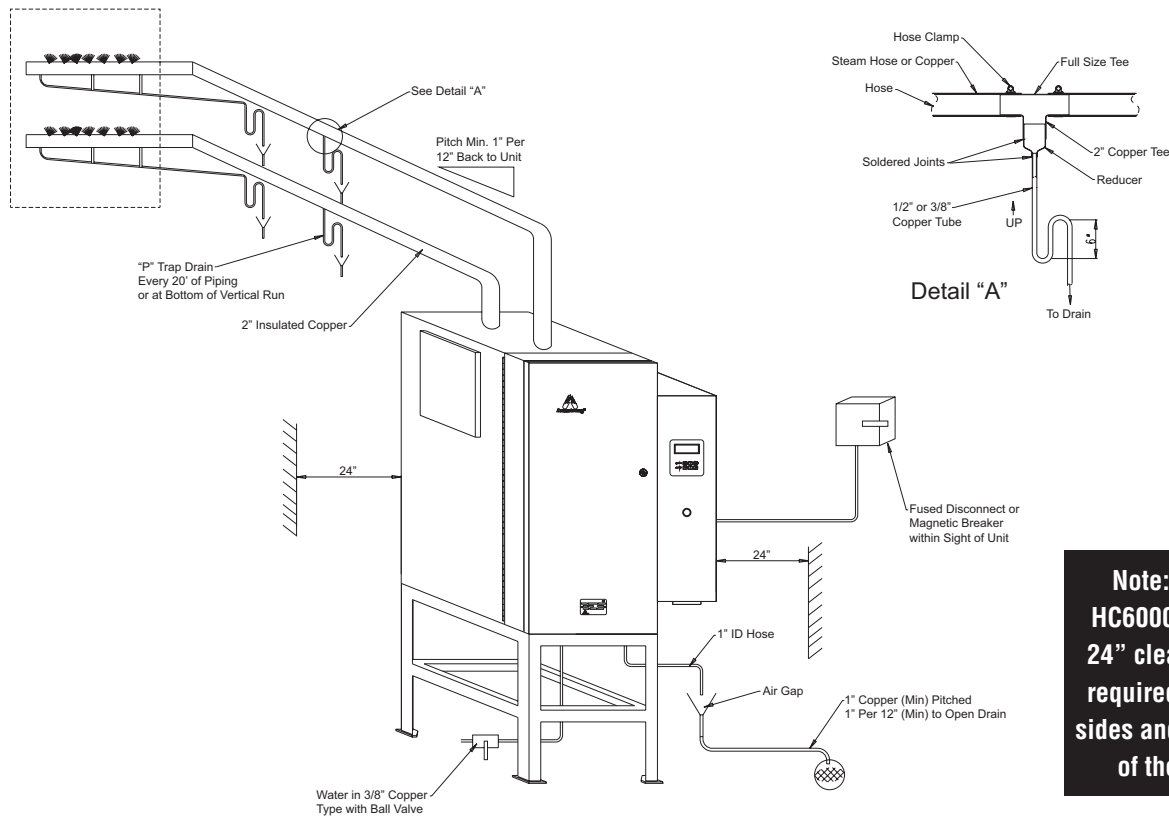

Figure 6-2 HC-6500/6700 Installation



HC-6100/6300 Mounting

The HumidiClean™ models HC-6100/6300 are designed to be wall mounted. A wall mounting bracket and lag screws are provided for mounting on 410 mm (16") centers. The operating weight of the unit is 106 kg (233 lbs). A clearance of 600 mm (23") on the front and sides of the cabinet is required for servicing.

1. Position wall mounting bracket level on wall and mark the hole pattern. Make sure holes line up with studs or other sturdy structure.
2. Use 3/8" x 1-1/2" lag screws provided to secure the bracket.
3. Hang the humidifier on the wall mounting bracket. The dry weight of the unit is 70 kg (154 lbs).

HC-6500/6700 Mounting

The HC-6500/6700 HumidiClean™ is designed to be floor mounted on a level surface. The operating weight is 230 kg (507 lbs), a clearance of 610 mm (24") is required for the front and sides.

Water Fill Supply

The humidifier can use any potable or purified water supply. Water pressure must be 25-120 psig. Water temperature must be less than 60°C (140°F). The fill rate is .31 GPM for HC6100/6300 and 1.2 GPM for HC6500/6700 units.

1. Install a shut-off valve near the unit.
2. Connect the water supply to the 3/8" compression fitting on the fill water solenoid valve on models HC-6100/6300. The HC6500/6700 is supplied with a compression fitting for 10mm plastic tubing. A 6' piece of 10mm plastic tubing is included for the larger models. The access for the water supply tubing is under the fill valve in the bottom wall.

Electrical Service Wiring

1. Connect main power supply wiring to high voltage terminals in unit. Read breaker size required on humidifier's nameplate and refer to Table 8-1 and 8-2 for HC-6100/6300 wire (gage) required; Table 8-3 and 8-4 for HC-6500/6700. Make sure an interlocking circuit breaker or safety switch (not furnished) is accessible and within sight of the unit.
2. The humidifier cabinet must be grounded. A ground lug is provided in the cabinet.
3. Use only wire with copper conductors rated at 90°C (194°F) or higher for power supply and grounding.

Table 8-1. Recommended Branch Circuits

Rating Amp	1-12	13-15	16-20	21-24	25-32	33-40	41-48	49-64	68-80	81-100	101-120	121-140	141-60	
Wire	(AWG)	14	12	10	10	8	8	6	4	3	1	0	0	0
	(mm2)	3	4	6	6	10	10	16	25	35	50	50	70	95
Circuit Breaker		15	20	25	30	40	50	60	80	100	125	150	175	200

Table 8-2. Steam Capacities and Rating Amperages

Volts (Vac)	HC6100/HC6100DI						HC6300/HC6300DI								
	3 KW Unit			9 KW Unit			15 KW Unit			18 KW Unit			30 KW Unit		
	Nominal Amperage Rating		Steam Output kg/hr (lb/hr)	Nominal Amperage Rating		Steam Output kg/hr (lb/hr)	Nominal Amperage Rating		Steam Output kg/hr (lb/hr)	Nominal Amperage Rating		Steam Output kg/hr (lb/hr)	Nominal Amperage Rating		Steam Output kg/hr (lb/hr)
	Phase			Phase			Three Phase			Three Phase			Three Phase		
	Single	Three		Single	Three		Three Phase	Three Phase		Three Phase	Three Phase		Three Phase	Three Phase	
208	13.3	7.7	3.8 (8.3)	39	23	11 (24)	37	18 (40)	46	22 (48)	74	36 (80)	41 (90)		
240	12.9	7.5		38	22		36		44					72	
200	-	4.7		-	14		23		28					46	
480	-	3.8		-	11		18		22					36	
600	-	3		-	9		15		18					30	

Table 8-3. Steam Capacities and Rating Amperages

Volts (Vac)	HC6500/6500DI									
	30 KW Unit		33.5 KW Unit		40 KW Unit		48 KW Unit		45 KW Unit	
	Nominal Amperage Rating Three Phase	Steam Output kg/hr (lb/hr)	Nominal Amperage Rating Three Phase	Steam Output kg/hr (lb/hr)	Nominal Amperage Rating Three Phase	Steam Output kg/hr (lb/hr)	Nominal Amperage Rating Three Phase	Steam Output kg/hr (lb/hr)	Nominal Amperage Rating Three Phase	Steam Output kg/hr (lb/hr)
208	84	41 (90)	-	-	-	-	-	-	125	61 (135)
240	-	-	-	-	96	54 (120)	-	-	-	-
400	-	-	51	45 (100)	-	-	73	65 (144)	-	-
480	-	-	-	-	-	-	58		-	-
600	-	-	-	-	-	-	47		-	-

Table 8-4. Steam Capacities and Rating Amperages

Volts (Vac)	HC6500/6500DI						HC6700/HC6700DI	
	50.3 KW Unit		60 KW Unit		72 KW Unit		96 KW Unit	
	Nominal Amperage Rating Three Phase	Steam Output kg/hr (lb/hr)	Nominal Amperage Rating Three Phase	Steam Output kg/hr (lb/hr)	Nominal Amperage Rating Three Phase	Steam Output kg/hr (lb/hr)	Nominal Amperage Rating Three Phase	Steam Output kg/hr (lb/hr)
240/220	-	-	144	82 (180)	-	-	-	-
400/380	77	30 (68)	-	-	110	98 (216)	145	130 (288)
480	-	-	-	-	87		116	
600	-	-	-	-	70		93	

Drainage

Connect HC-6000 drain to suitable waste drainage system. HC-6100 and HC-6300 drain water may be as hot as 70°C (158°F), HC-6500 and HC-6700 may be as hot as 57°C (135°F). Use clear drain hose provided and 25 mm (1”) copper pipe pitched away from unit at 25 mm (1”) inch per foot. An air gap to prevent back flow is required. See Figure 8-1.

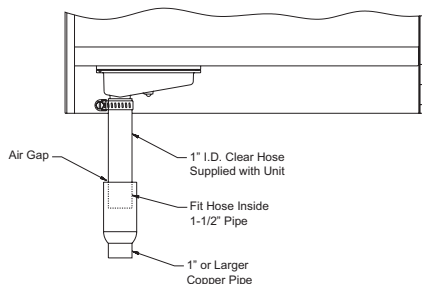

Figure 8-1 HC-6100/6300/6500/6700

Duct Steam Distribution

1. The dispersion tube should be proper length. Verify correct size from Table 9-1.
2. Install dispersion tube(s) horizontally in duct so holes face upward. Air flow must be vertical up or horizontal. Do not restrict duct with a height of 200 mm (8") or less. Installations over 10 m/s (1800 FPM) air velocity are not recommended. Consult factory if air flow is vertical down or air velocity is over 10 m/s (1800 FPM). Do not install in ducted systems with total back pressure exceeding 150 mm (6"), wc. Airflow should be a minimum of 250 FPM for installations using dispersion tubing. Consult factory if velocity is below recommended level.
3. The dispersion tube(s) should be located upstream of a straight duct run, without obstructions, 3 m (10 feet) or more in length. Consult the factory if this distance is not available.
4. Cut 2-3/8" (61mm) dispersion tube installation hole. Fasten the mounting plate to duct with sheet metal screws. If the dispersion tube is 900 mm (35") or longer, support the far end with threaded rod or similar means.
5. **Note:** For steam being generated from a deionized (DI) or reverse osmosis (RO) water source, the use of 50 mm (2") insulated stainless steel piping in lieu of copper is required. Pipe used for steam dispersion piping must be oil and contaminate free. Premature element failure could result if oils or contaminants are present. Contact the factory with questions. Connect dispersion tube(s) to HumidiClean™ tank using 50 mm (2") nominal insulated copper pipe and hose cuffs provided. We do not suggest steam distribution piping of field supplied rubber based compounds to be used for any HumidiClean™ application. Pitch pipe back to unit 25 mm (1") per foot. The steam pipe must be free of kinks and sags to allow for gravity drainage of condensate. Maximum pipe run distance from tank to dispersion tube is 12 m (40 feet) equivalent piping length. Avoid excessive use of elbows or 45° changes in direction. A "P" trap should be installed every 6 m (20 feet), of piping run or at the bottom of vertical runs that cannot drain back to the tank. See Fig. 6-1 or 6-2 for piping detail.
6. If duct static pressure plus piping back pressure is greater than 0.5 in HG (6" WC), please consult the factory. (See Figure 9-1 for back pressure in pipe run.)

Model HC6100, HC6100DI	Model HC6100, HC6100DI "D" Dia.	Model HC6300, HC6300DI, HC6500, HC6500DI, HC6700, HC6700DI	Model HC6300, HC6300DI, HC6500, HC6500DI, HC6700 DI "DL" Dia.	Steam Disp. Tube Length "L" mm (in)	Duct Width	
					Minimum mm(in)	Maximum mm (in)
D-1	1-1/2"	DL-1	2-3/8"	305 (12)	280 (11)	406 (16)
D-1.5		DL-1.5		457 (18)	432 (17)	559 (22)
D-2		DL-2		610 (24)	584 (23)	864 (34)
D-3		DL-3		914 (36)	889 (35)	1168 (46)
D-4		DL-4		1219 (48)	1194 (47)	1473 (58)
D-5		DL-5		1524 (60)	1499 (59)	1778 (70)
D-6		DL-6		1829 (72)	1803 (71)	2083 (82)
D-7		DL-7		2133 (84)	2108 (83)	2388 (94)
D-8		DL-8		2438 (96)	2413 (95)	2692 (106)
D-9		DL-9		2743 (108)	2718 (107)	2997 (118)
D-10	DL-10			3048 (120)	3023 (119)	3302 (130)

Fitting Style	Equivalent Linear Piping (feet)
2" - 45° Elbow	2.8
2" - 90° Elbow	5.5
2" - 90° Long Elbow	3.5
2" - Tee	12

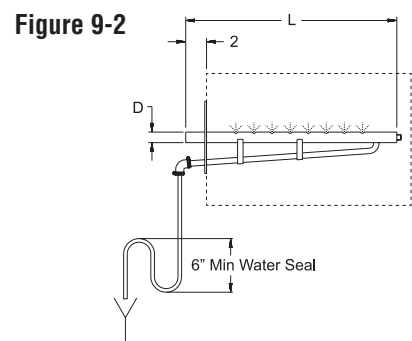
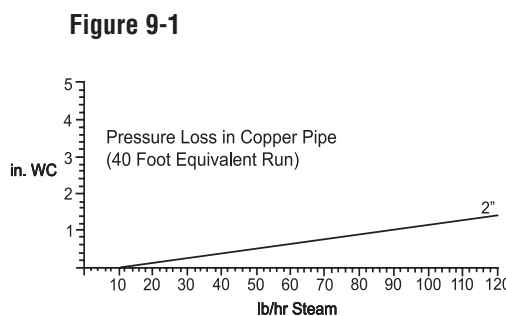

Area Steam Distribution

The EHF-3 fan package (minimum of 2 required for HC-6500 or 3 for the HC-6700) is designed to be hung on a wall to operate as a remote mounted, direct area discharge option. It incorporates a blower rated at 120v- 1.28 amps. CFM rating is 463 @ 1600 RPM. The fan package requires a separate 120 volt power supply (optional step down transformer available). Consult Armstrong Installation Bulletin IB-95 for more information.

Alternative for shortened non-wettable vapor trail

For applications with particularly limited downstream absorption distance, Armstrong HumidiPack™ or ExpressPack may be considered. HumidiPack™ is a prefabricated separator/header and multiple dispersion tube assembly. ExpressPack is a multi-tube steam dispersion panel which is shipped unassembled. The Armstrong HumidiPack™ or ExpressPack provide uniform distribution and shortened non-wetting vapor trail. Consult Armstrong Installation Bulletin No. 560 or Bulletin 573 for more information.

Control Wiring

When knock-out for sensor wiring is removed, an IP65 compliant cable bushing will be required to keep the electric cabinet in compliance with IP32.

Wiring for low voltage controls should not be run in same conduit as the power supply. Use of shielded wire or a separate dedicated metal conduit is required. When shielded cable is used, shield is to be grounded at the humidifier only. The wire should not be longer than 30 meters (100 ft). If the wire is out of this limit, please contact Armstrong. Refer to Figures 11-1 and 11-2 for wiring schematics.

Control Humidistat

1. Locate control humidistat where it will sense the average air condition of the space to be humidified. Avoid areas of restricted circulation or locations where the sensor will be subjected to drafts, localized heat or moisture sources.
2. Optional duct mounted humidistats are available to sense return or exhaust air, if preferred.
3. Set DIP switch S-2 on the PC board to the proper range for the humidistat control signal to be used. Also set voltage source Berg Jumper S3 to proper range. See Fig. 10-1 for location of switches and pages 10 and 11 in tandem with the applicable wiring diagram below for correct switch settings.

Figure 10-1

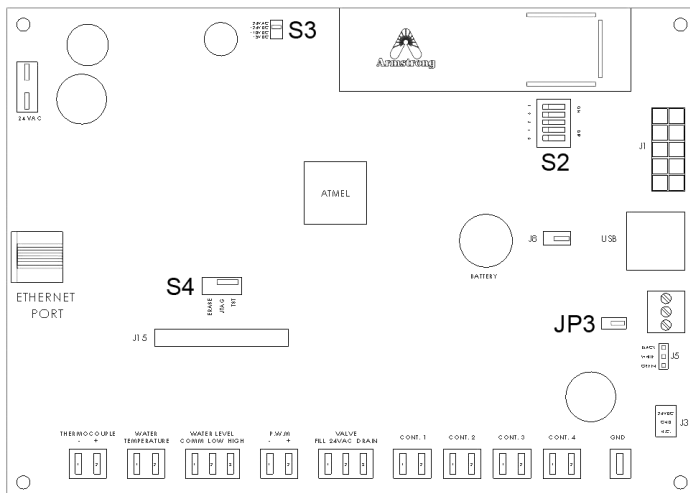
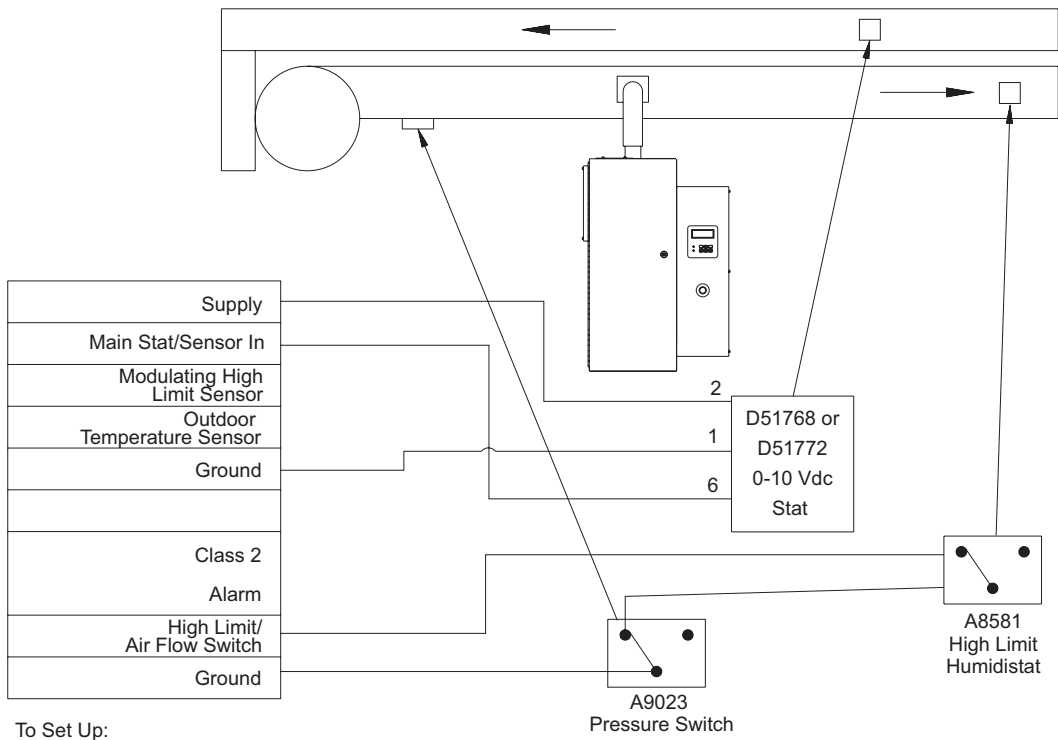
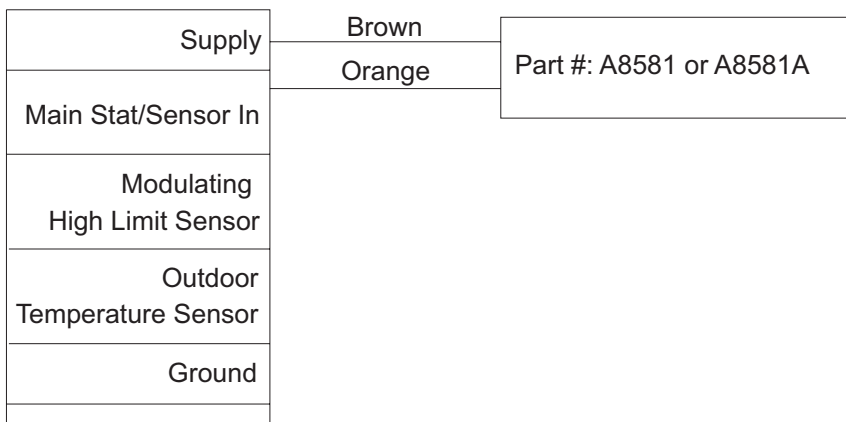

Figure 11-1
Standard Humidistat



- To Set Up:
- 1) S3 - 24 VAC (Top Position)
 - 2) S2-1, 2, 3, 4, 5 Off
 - 3) Select 0-10v "Signal" in the Setup Menu.
 - 4) Select Humidistat "Sensor" in the Setup Menu.

Figure 11-2
On/Off Humidistats



- 1) S3 to + 10vdc
- 2) S2 Off (All)

Figure 12-1
0-10 Vdc or 4-20mA Control Signal

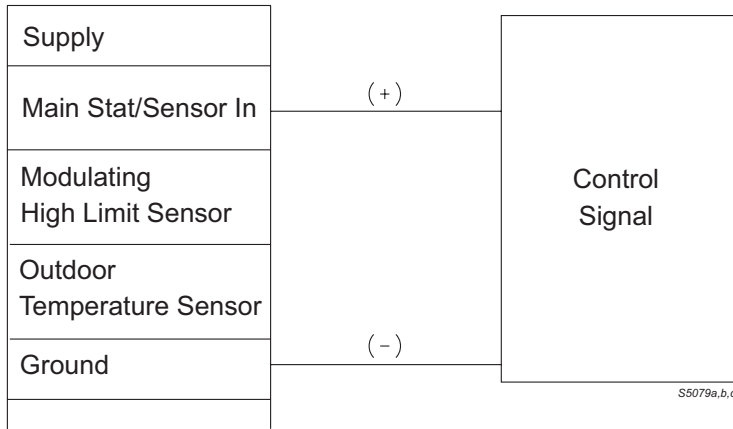

- 4-20ma Setup or 10 vdc Setup
 1) S2-1, 2, 3 On if 4-20ma
 2) S2 Off (All) If 0-10vdc
 3) Select Corresponding Signal
 Type In Setup Menu.

Figure 12-2
RH Sensors/Transmitters

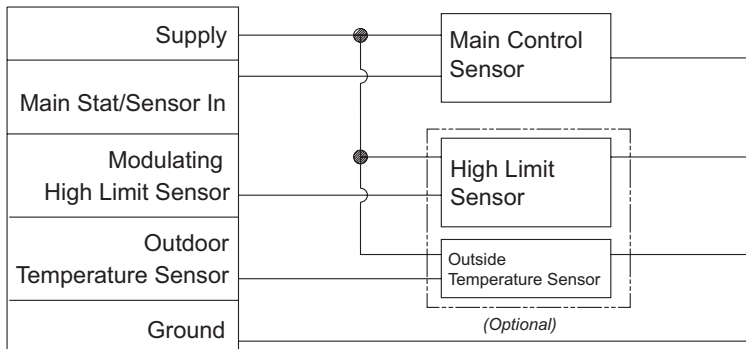

Chart 12-3 Jumper and Dip Switch Settings	
S3: Voltage Selector from the Humidifier to the Stat	Pins 1&2- 24vac
	Pins 3&4- 24VDC
	Pins 5&6- 10vdc
	Pins 7&8 5vdc
S4: code erase and code write	To Erase, place the jumper on pins 1&2. Leave the jumper on pin 4 during operation.
S2 Dip Switch:	1,2,3 ON – Current Input
	1,2,3 OFF – Voltage Input (DC)
	4,5 OFF – NO Outdoor Temp in
	4 Off 5 ON – Out door Temp In
	4 ON 5 OFF NTC In
	4 ON 5 ON – N/A
J8 Jumper	Pins 1,2 Write to Project
	Pins 2,3 Read/Write

High Limit Humidistat

Remove the jumper tab from ground and in of high limit/pressure switch connections and wire the high limit stat between these terminals. Refer to Figure 11-1 (the overall wiring diagram) for more information. A duct mounted high limit humidistat is recommended to prevent over-saturation of the duct air. Use an on-off controller that opens on fault (high humidity). Humidistat should be set for a maximum of 90% RH. Locate the high limit humidistat approximately 3m (10 feet) downstream of the dispersion manifold. If 3m (10 feet) is not available, consult the factory. **Note:** High limit humidistat will be wired in series with duct pressure switch, if used, see Figure 11-1.

Airflow/Pressure Switch

An airflow switch is recommended to deactivate the humidifier when there is insufficient air flow in a duct system. A duct pressure switch is preferred as an airflow sensor. The pressure switch should open on insufficient airflow (opens on fault). Airflow switch should be mounted in supply air duct upstream of humidifier dispersion. Remove the jumper tab from ground and in of high limit/pressure switch connections and wire the airflow sensor between these terminals. See Figure 11-1 (the overall wiring diagram) for more information. Complete installation and wiring instructions are contained in the duct pressure switch package.

State light will flash green if either high limit or air pressure switches are open.

Modulating High Limit Humidistat/Sensor

A modulating high limit humidistat may be used on applications such as Variable Air Volume (VAV) or in situations where the duct RH required to maintain the room set point is near saturation. The modulating high limit alleviates the humidifier from operating in on/off if working near the high limit set point. See Figure 11-1 or Figure 12-2 for wiring.

Alarm Circuit

The terminals 3 & 4 (normally open relay external alarm) are connections for a class II NEC alarm circuit (switch closure only, 1 amp. maximum @ 24 Vdc or 0.5 amp. @ 125 Vac). The switch will close if the unit encounters an error or when service life has expired it will not engage if high humidity/sail switch circuit is open.

Display Menus

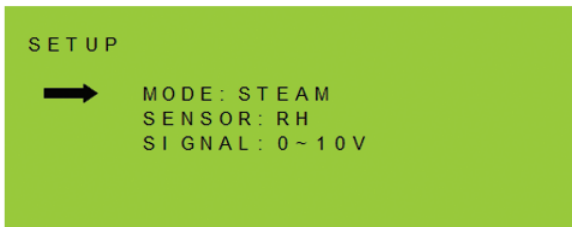
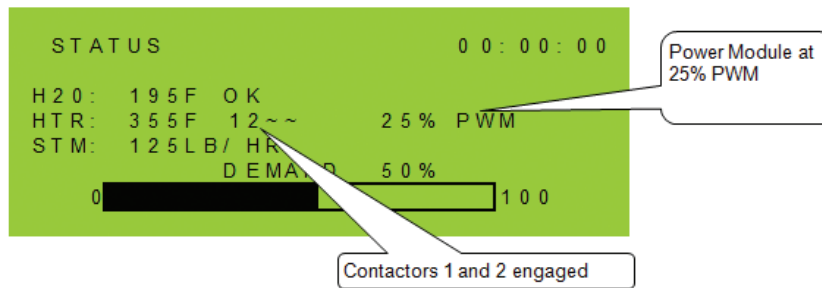
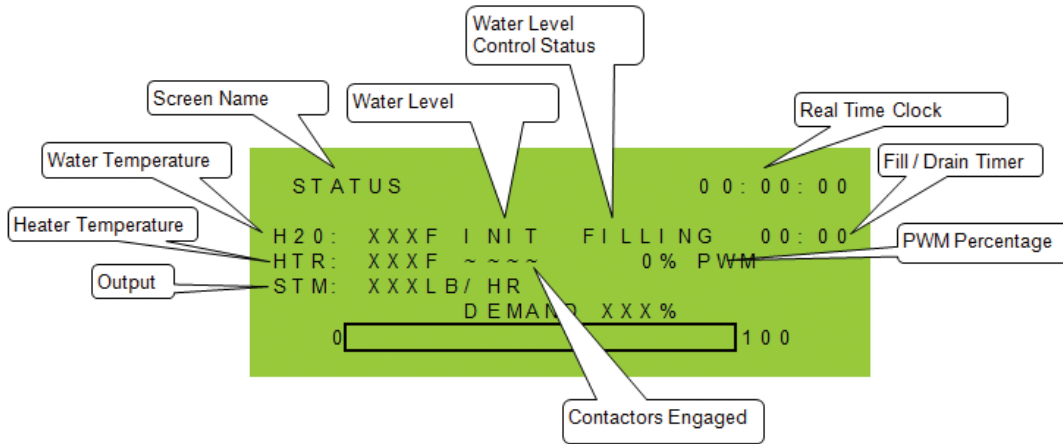

MODE: Steam
Manual Drain
Manual Fill
STOP

Sensor: RH
Humidistat
ON/OFF

Signal: 0-10V
0-5V
4-20 mA

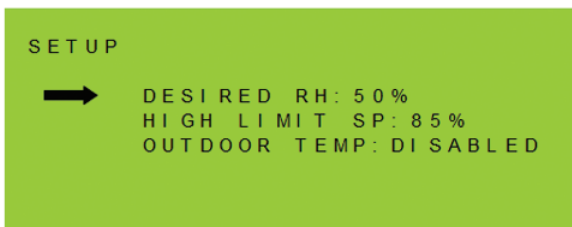

Desired RH: Setpoint required when RH Sensor is being used as main control.

High Limit SP: Modulating High Limit setpoint when MHL sensor is being used. Set to DISABLED if no MHL sensor is being used

Outdoor Temp: When enabled, ability to set high and low temperature setpoints for outdoor temperature reset function.

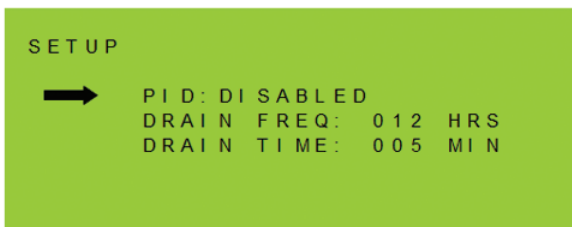

PID: When enabled, ability to set all PID values
PB
IRV
DG
SI

Drain Freq: Time period between drains in hours (0-96)

Drain Time: Drain time in minutes (1-15)

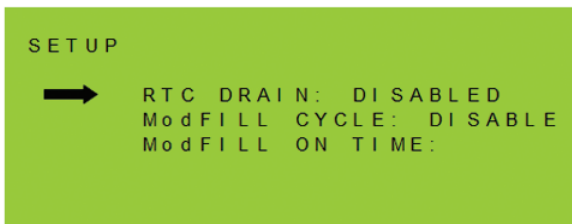

RTC Drain: When enabled, ability to set drain time based on real time clock
Drain time will be timer set above

ModFILL Cycle: When enabled, ability to set modulating fill cycle time (15-30)

ModFILL on time: timer for amount of time fill valve is on during ModFill Cycle time (0-20)

```

SETUP
  → AQUASTAT: 040 °F
    EOL: 1000 HOURS
    NETWORK MODE: MODBUS

```

Aquastat: Aquastat setpoint temperature (DIS - 180F)
 EOL: End of service life (DIS - 3000 in 250 hr inc.)
 Network Mode: MODBUS
 PSP

```

SETUP
  → NETWORK CONT: MONITOR
    BAUD RATE: 19200
    PARITY SELECT: EVEN

```

Network Control: Monitor - Only view information
 HSTAT - Send control signal and change values
 SENSOR - Send control setpoint and change values
 FULL - Full control, send output and change values
 Baud Rate: 9600
 19200
 Parity Select: Even
 Odd
 None

```

SETUP
  → COMM ADDRESS: 001
    LIST XX ERRORS
    CLEAR ERROR LOG

```

COMM Address: Sets address for MODBUS only. Should be 001 for PSP
 List XX Errors: Unit stores error log. This allows user to recall them
 Clear Error Log: Clears error log

```

SETUP
  → SET CLOCK
    LOAD DEFAULTS
    RESET EOL?

```

Set Clock: Sets date and time for real time clock
 Load Defaults: resets existing configuration to default settings.
 Reset EOL: Resets the EOL timer to 0

```

CONFIG
  → CONTACTORS: 1
    POWER: 1000W
    CAPACITY ADJ: 100%

```

Contactors: Number of contactors (1-4)
 Power: kW rating of elements
 1000 3000 5000 6650 8000
 Capacity Adj: Sets a multiplier for the maximum output of the unit

```

CONFIG
  → H2O COMP X F
    HTR COMP X F

```

H2O COMP: Used to calibrate water temp sensor
 HTR COMP: Used to calibrate heater temp sensor

Start-Up Procedures and Operation

The HumidiClean™ humidifier converts ordinary tap water or purified water to steam for distribution to raise the relative humidity level. The demand for humidity is sensed by a humidistat or sensor which sends a control signal to the HumidiClean™. The HumidiClean™ is connected to the power supply (208, 220/240, 380/400, 480 or 600 Vac) through a separate circuit breaker supplied by the customer. When power is initially supplied to the unit from the circuit breaker, the LCD will display “ARMSTRONG HC6000”. The “POWER” LED will come on and the unit’s fill valve solenoid is energized to allow water to enter the tank at a rate of 1.2 L/min (.31 GPM) (HC-6500/6700 fill rate is 3.735 L/min (1 GPM)). **Note:** When unit is turned on the drain valve will energize for 6 sec. or until water level drops below the high water probe. If water level in tank is above the low water level switch, assuming the air proving switch is close, the high limit humidity switch is closed, the heating elements will be activated.

The water fill solenoid continues to be activated until the water level in the tank has energized the high water switch. **Note:** If fill or drain valves are not energized when power is first applied, check LCD for diagnostic code. See DIAGNOSTICS section. The heating elements will remain on to preheat the water inside the tank until the temperature of water has reached the aquastat set point. During this preheat cycle the amperage draw of the tank can be checked with a clamp on amp meter. The amperage draw on all high voltage wires connected to the main power supply terminal block should correspond to the value on the nameplate. If aquastat has been disabled, the humidifier will go into a 3 minute warm-up once the water hits the low water probe.

After the heat-up time, the HumidiClean™ will continue to produce steam based on the demand signal, read from the humidistat or calculated by reading the relative humidity and setpoint. If the demand signal drops below 2% or the high limit/sail switch circuit opens, the contactor(s) will open and the unit will idle. **Note:** If the humidifier shuts off due to low humidistat demand, a demand signal of 4% or greater is needed to re-initiate steam generation. If all the signals are consistent as stated above, HumidiClean™ will produce steam continuously and refill the tank with water when the low water level is reached. These fill intervals will operate based on modulating fill settings in software.

Power to the heating elements is switched on and off by the triacs in the power module to achieve a modulating output based on the demand signal. The triac utilizes a 1/2 second cycle time. For example, with a 50% humidistat demand signal the triacs would be on for 1/4 second and off for 1/4 second. If the triacs are fully on, the green “SIGNAL” LED on the power module will be on constantly. When the triacs start to modulate (switch power to the heating elements on and off) the LED will show the triac on condition and will appear to flicker or blink.

As HumidiClean™ continues to produce steam, the unit will accumulate and memorize the heating element active time for the purpose of defining a drain cycle and service life (this memory is not affected by power outages). When the HumidiClean™ heating elements have been on for the drain frequency setting, the unit activates the drain and fill solenoids and begins draining the tank. The tank will drain with the water being tempered from an activated water fill solenoid. The drainage from the tank will pass the low water switch, opening the switch and shutting off power to the heating elements. The drainage from the tank should not exceed 70°C (158°F) on the HC-6100 and HC-6300, or 57°C (135°F) on the HC-6500 and HC-6700. The drain cycle is controlled by the user inputted values in the operation setup menu. Once the unit has timed out of the drain cycle and all of the switches are still in position to generate steam, the water fill solenoid switch is activated to fill the tank and the cycle starts over again.

Maintenance

When 90% of the setting service time has accumulated, the “STATE” LED on the control panel will blink in yellow. (Refer to EOL settings, for bed life duration settings). If the HumidiClean™ is not serviced at this time; the unit will continue to operate for the remaining 10% of the service life setting. When 100% of the bed life setting has been reached, the “**STATE**” LED will be on in red. The unit will drain the tank and not respond to a call for demand.

Note: Service Life can be adjusted based on water quality. If Ionic Beds are relatively free of scale deposits or scale is forming on tank walls and elements because beds are saturated with scale, please consult the factory for Service Life adjustment procedures.

A. Servicing the Unit

1. Enter the **SETUP** menu

2. Scroll to **Mode**

- a. Drain tank by changing from “**STEAM**” to “MANUAL DRAIN” in the Setup Menu.
- b. Once the tank is drained, shut power off to unit and allow the tank to cool.
- c. Remove the cabinet access panel and tank access panel, located on left side of humidifier.

3. **Ionic Bed Inspection**

Remove and inspect one of the ionic beds and inspect the drain screen at the bottom of the tank. If the bed does not appear to be saturated with mineral deposit (a full bed will weigh 1.1 kg (2.42 lbs) dry and if the drain screen is clear, you can reset the Ionic Bed life timer and either change that timer or leave it as it was. Continue on to Step 4.

If the beds are saturated, remove all of them. Remove any large pieces of scale from the tank. See Page 18 (Replacing the Ionic Beds) for complete instructions.

4. **Cleaning the Unit**

- a. Chemically clean the unit with Rite-Qwik. (If desired.)
 - i. Pour 3.75L (1 gallon) of Rite-Qwik into tank followed by 3.8 L (1 gallon) of fresh water. The HC-6500/6700 model requires 7.6 L (2 gallons) of Rite-Qwik and 7.6 L (2 gallons) of water.
 - ii. Allow the solution to work until the bubbling action ceases, not to exceed 1 hour. While waiting you can proceed with Steps b, c and d.
 - iii. Fill the tank with water and drain. (Perform this step several times.)
- b. Clean the water level electrodes, using an emery cloth. See Page 20 for complete instructions.
- c. Ensure drain lines are free of leaks and secure.
- d. Check inlet screen on fill valve and remove any debris.
- e. Install the new Ionic Beds once you flushed the tank out.

5. **Restoring the Unit to Operation**

- a. Turn power on at breaker.
- b. Unit should begin to fill. Maximum fill time is approximately 30-45 minutes before contactor(s) will be closed.
- c. Go into the Setup menu and verify that the unit is in “Steam Gen”.

6. **Resetting the EOL Timer**

- a. Enter Setup menu.
- b. Scroll to “Reset EOL?”.
- c. Press enter to reset the EOL timer to 0 .

7. **Modifying the Bed Life Setting**

1. Complete the steps for servicing the unit as outlined above.
2. Change the EOL settings to desired value in Unit Status menu.
3. Save settings in menu.

End of Season Drain

If at any time during normal operation there is not a demand for a continuous 72 hour period, HumidiClean drains the tank and the PC Board initiates a drying cycle by cycling the heating elements for short intervals in order to dry the ionic beds.

Replacing the Ionic Beds

1. Enter the **SETUP** menu
2. Scroll to **Mode** Menu
 - a. Drain tank by operating menu from “STEAM GEN.” to “MANUAL DRAIN” position.
 - b. Once the tank is drained, shut power off to unit and allow the tank to cool.
 - c. Remove the cabinet access panels, and slowly open tank access panel.
3. Unsnap ionic beds from support pins and slide them out through the access opening.
4. Inspect tank drain screen and elements inside the tank. The elements should appear to be flaking off scale. If the drain screen appears to building deposits in the screen holes it should be cleaned. Remove any scale that appears in the bottom of the tank.
5. Install six (6) new ionic beds (14 for the HC-6500/6700), snapping them into place on the support pins.
(Pinch ends to secure.)
6. Make sure access panel gasket is lapped over all edges of tank access opening. Replace and secure tank access panel.
7. Make sure both access doors/panels are secure.
8. Turn on power at circuit breaker.
9. After the unit has heated up and started making steam, turn main power off and double check tank access panel gasket for steam leakage. Hand tighten wing nuts or reposition gasket if necessary.

Figure 19-1 HC-6100/6300

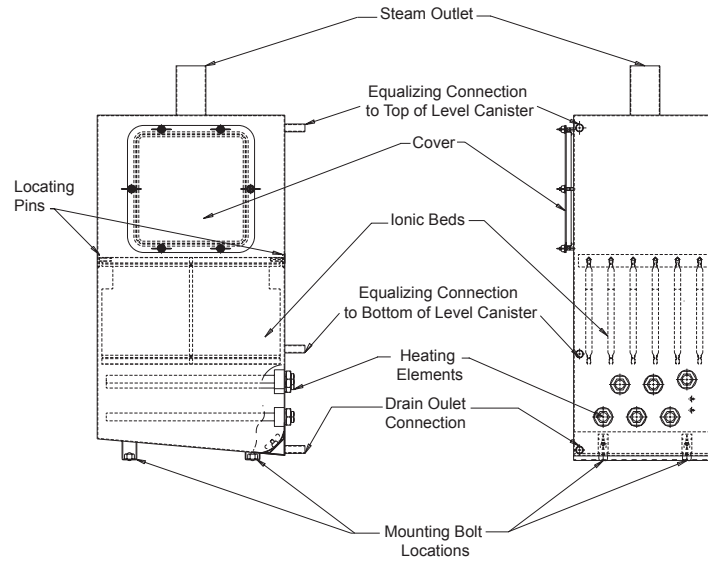
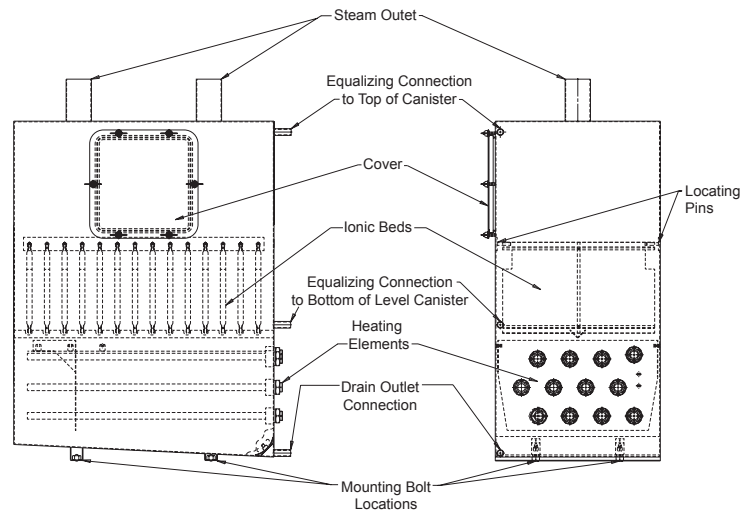
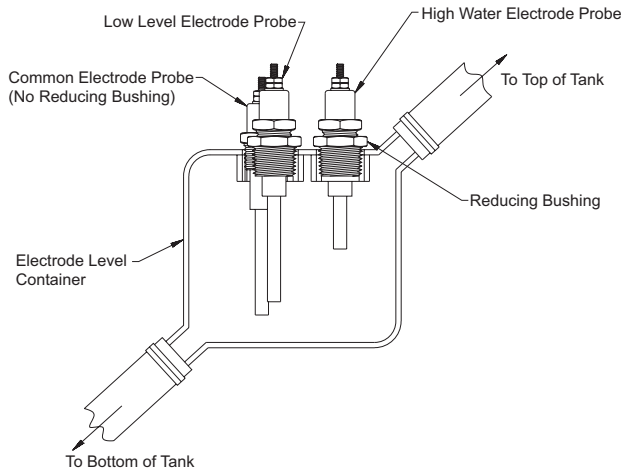

Figure 19-2 HC-6500/6700



Cleaning the Water Level Electrodes

1. If there is water in the steam generating tank, operate the “SETUP”, “MODE” menu to “MANUAL DRAIN”. The drain valve should energize, and the unit should completely drain.
2. After the tank has drained, turn off the main power at the disconnect.
3. Unclamp and remove the 5/8” ID Silicone tubing from the top outlet of the level canister.
4. Disconnect wires #21 (high level probe), #20 (low level probe) and #19 (common probe) from the probes, noting the probe and wire locations. **Note: Level control float switches are used for DI, RO, or very pure water. Cleaning should not typically be required.**



5. Unscrew the probes from the level canister using the hex nut fitting on the probe (Note: Level canister bushings may be removed with the probes, if necessary).
6. Use a wire brush, wire wheel, or similar means to clean scale deposits off the stainless steel tip of the probe. Cleaning of the Teflon insulating jacket (white portion) should not be needed.
7. Wipe probes with a clean dry cloth.
8. Inspect the interior of the level canister. If large amounts of scale or debris are present, remove the canister from the cabinet by removing the two clamping bracket screws and disconnecting the 5/8” ID Silicone hose at the bottom of the canister. Flush the canister with water to remove debris and reinstall.
9. Reinstall the probes and probe wires in their proper locations. The high water probe (shortest) goes in the right hole of the canister. The low water probe (medium length) goes in the left front hole of the canister. The common probe (longest) goes in the left, rear hole of the canister.
10. Reconnect the 5/8” ID Silicone hose(s).

Removing the Tank

1. Operate the “SETUP” menu to “MANUAL DRAIN” and allow unit to complete a deep drain. (**Caution:** Tank will still be quite warm).
2. Turn off circuit breaker.
3. Unlock and open front and side doors. Remove left side panel and top panel.
4. Disconnect 3 hoses from front of tank; rubber hose cuff at steam outlet; heating element leads at contactor, fuses, or power module; and thermocouple and aquastat wires.
5. Loosen and remove 4 mounting bolts at the bottom of tank. Slide tank out left side of cabinet (be sure tank had time to cool after operation).

Troubleshooting

Notice: This troubleshooting guide is offered to aid in servicing the HC-6000 humidifiers. It is intended for use by electricians and technical service personnel familiar with electrical and electronic equipment. Many steps in the troubleshooting procedures require measurements of high voltages and involve working near exposed live parts. **KNOW WHERE THE HIGH VOLTAGE PARTS ARE, AND KEEP HANDS AND METAL TOOLS AWAY FROM THEM.** All resistance checks should be made with main power OFF and the component disconnected from wiring. All continuity checks should be made with main power OFF. If unsure concerning any of the following procedures, PLEASE consult the Armstrong Humidification Group at (269) 273-1415.

Humidifier will not fill with water when power is applied.

1. Make sure the status in Setup menu “Mode” is in “Steam”.
2. If “STATE” LED is red, refer to MAINTENANCE or DIAGNOSTICS section of this manual.
3. Make sure “POWER” LED is lit. If not, check voltage at secondary side of the main power transformer. Voltage should be 24-28 VAC. No or low voltage is an indication of a problem with the supply voltage or transformer. Verify supply voltage and make sure it is the same as voltage rating on humidifier nameplate. Check secondary power fuses. Make sure that the emergency stop is rotated outwards.
4. Check the voltage to the fill valve. Voltage should be 24-28 VAC (voltage should be taken with wires connected). If voltage is present, fill valve solenoid coil is probably defective. Coil resistance should be 18W (8.3W for HC-6500/6700) with wires disconnected.
5. Check for water in cabinet bottom or in fill cup overflow line. If present, see “Water in bottom of cabinet” on page 25.
6. If no voltage is present to fill valve, check water level. If it is above 2/3 full in level canister, the drain valve has to open to drain water below high water level before the fill valve is energized.
7. Check for 24-28 Vac power to drain valve (voltage should be taken with wires connected). If power to drain valve is OK, check drain valve coil resistance with wires disconnected. It should be approximately 10 ohms (8.3 ohms HC-6500/6700).
8. If drain valve and fill valve are both energized and water is below the 1/3 full level in the electrode canister (float canister for DI units), make sure the status of “Mode” in the Setup menu is “STEAM”. Perform continuity check to be sure.
9. If drain valve only is energized and water level is below the 2/3 full level in electrode canister (float canister for DI units), there may be excessive debris in electrode canister (float canister for DI units). Inspect and clean if needed. See page 20 for Cleaning Procedure for Electrodes.
10. PC board may be defective. Consult the factory.

Humidifier fills with water, but does not show steam output for 3 minutes after reaching low water level.

1. Perform steps 1 through 3 from above “Humidifier will not fill...”
2. **For Tap Water:** Check AC voltage across the common electrode (longest) and the low level electrode (medium length). The voltage will be approximately 24 VAC if the circuit is open. When the water level closes, circuit voltage should drop to <5 volts.
 - (a) If voltage is not 24 VAC with circuit open, check continuity of wires from electrodes to PC board. If continuity is OK, the PC board is likely defective.
 - (b) If voltage is 17-20 VAC with circuit open, but does not drop when water contacts the two electrodes, the water may be too pure (consult factory) or if the voltage drops very slowly to about 5 volts then the electrodes need cleaning. See page 20 for cleaning procedure for electrodes.
3. **For DI Water:** Check continuity across the two wires to the low water float switch. If no continuity, switch may be defective or “hung up”. Make sure movement of switch is vertical so the float arm swings freely.
4. If high limit/sail circuit is closed, low water level circuit is closed, and there is a call for humidity, the status of steam generation should be “STEAM GEN.”. If not, PC board or wiring harness is defective.

Unit shows Steam Output after initial fill to low water level, but amperage draw check shows low or no amperage draw.

1. Check for line voltage to heating elements at secondary side of contactor and/or power module. Verify power supply is same as voltage rating on humidifier nameplate.
2. If voltage is correct, the heating elements are likely defective. Turn off main power, disconnect all elements and check element resistances (see resistance chart on Page 41). Look for open circuits or elements with high resistance.
3. If voltage is not present at elements, check primary voltage fusing.
4. If fuses are OK, check voltage to contactor coil.
 - (a) If voltage is 24-28VAC at contactor coil, check coil resistance. It should be 8 ohms with wires disconnected. If resistance is OK, check voltage drops across the contactor.
 - (b) If no voltage to contactor coil, check continuity of wires from PC board to contactor. If continuity is OK, PC board is likely defective.
5. Check voltage signal to power module. The voltage across TAB8-1 and TAB8-2 (low voltage signal to power module) should be 12 Vdc at 100% demand.
 - (a) If no or low voltage, the PC board is likely defective.
 - (b) If voltage is OK, but green “SIGNAL” LED on the power module is not on, power module is defective.
6. If green “LOAD” LED on power module is on, check voltage drops across power module.

Humidifier overfills with water on initial fill..

1. Check electrode canister (float canister for DI units) and level electrodes for debris or scale build up. Clean as needed. See Page 20 for cleaning procedure for electrodes. On DI Units, the high water float switch may be defective or “hung up”. Check continuity across wires to the switch. Make sure switch movement is vertical so float lever arm swings freely.
2. The fill valve may be stuck open. Turn off power to the humidifier. If fill valve does not close, clean or replace valve.
3. If the high water circuit is closed and the fill valve shuts off when the power is turned off, the PC board is defective.

Humidifier runs continuously, %RH is well over set-point.

1. Verify humidistat signal isn't sending false 100% demand.
2. Verify humidistat or RH sensor is wired correctly and stat/sensor jumper and dip switches (S2 & S3, See Fig. 11-1 and 12-1) on the PC board are set correctly for the humidistat signal.
3. If humidifier generates steam with the humidistat disconnected.
 - (a) Check for power at the contactor coil. If 24-28 VAC, PC board is defective.
 - (b) Check voltage drop across contactor. If voltage drop is low (it should be line voltage), remove, disassemble and inspect contactor.
 - (c) Check green “SIGNAL” LED on power module. If it is ON or blinking, PC board is likely defective.
 - (d) Check voltage drop across power module. If voltage drop is low (it should be line voltage), power module triacs may be failed closed. Shut off main power and perform continuity check across high voltage input and output terminals. Continuity indicates a shorted triac. Note: Some power modules have two triacs rather than three. Check schematic on power module to verify.
 - (e) Check to see if the aquastat is reading a value lower than the aquastat temp setting.

Humidifier runs continuously, %RH is well under set-point.

1. Verify humidistat/RH sensor is wired correctly and dip switches (S2 & S3, See Fig. 11-1 and 12-1) on the PC board are set correctly for the humidistat signal.
2. Check humidistat demand signal at low voltage terminal strip. It should be close or at 100%.
3. If humidifier is a three phase model, verify all three phases of power are present and equal.
4. Check amperage draw on all high voltage power lines with a clamp on amp meter. They should be same or very close to amperage rating on the humidifier's nameplate if the humidistat demand is 100%.
5. Turn off power. Disconnect heating elements and check resistances - see Tables on Pages 38 and 41. If an open circuit or abnormally high resistance is measured, the heating element(s) is defective. Also, check to see if heating element leads have shorted to ground.
6. If heating elements are OK, check voltages at secondary side of the power module and contactor. If no or low voltage, check primary fusing.
7. If fuses are OK, check voltage to contactor coil.
 - (a) If voltage is 24-28VAC at contactor coil, check coil resistance. It should be approximately 8W? with wires disconnected. If resistance is OK, check voltage drops across the contactor.
 - (b) If no voltage to contactor coil, check continuity of wires from PC board to contactor. If continuity is OK, PC board is likely defective.
8. Check voltage signal to power module. The voltage across TAB8-1 and TAB8-2 (low voltage signal to power module) should be 12 Vdc at 100% power.
 - (a) If no or low voltage, the PC board is likely defective.
 - (b) If voltage is OK, but green "LOAD" LED on the power module is not on, power module is defective.
9. If green "SIGNAL" LED on power module is on, check voltage drops across power module.
10. If supply voltage and amperage draws are correct and elements appear OK, unit is probably undersized (not enough capacity for the application). Check sizing or consult factory.

Humidifier does not drain when manual drain.

1. Disconnect and check resistance of drain valve coil. Resistance should be approximately 10 Ω (8.3 Ω HC-6500/6700).
2. Make sure drain line is pitched and sized correctly. Check for blockage or obstructions in the drain line. An air gap or funnel must be used as described in Drain Line Section. - See Figure 8-3.
3. If humidifier does not drain at specified interval or when service is to be performed and drain valve and piping appear OK, there is blockage of the tank drain screen or the PC board may be defective.
4. Make sure high limit/airflow circuit is closed.

Dispersion tube spits water or water is present in duct

Hint: It is very helpful to cut a small observation window in the duct and cover it with Plexiglas so the steam discharge from the manifold can be observed. This way the problem can be narrowed down to piping/steam quality (steps 1 and 2) or a condensation problem (steps 3 and 4).

1. Check distribution piping for proper pitch and size. Make sure there are no loops, dips or sags where pockets of water can collect. If such conditions exist and are unavoidable, a 'P' trap is needed to drain the low spots.
2. Make sure any drains are piped correctly and pitched to a floor drain.
3. Check duct downstream of manifold. If any obstructions (coils, elbows, fans) are within 10', the vapor (condensed steam) discharged from the manifold may be impinging on the obstacle before it has a chance to absorb into air. This is especially true if the duct air is cold (<50°F), duct air velocity is high (>2000 FPM), or duct %RH is high (>90%). If these conditions exist and impingement is suspected, consult factory.
4. The duct air may be saturated with moisture (100% RH). A high limit humidistat/RH sensor is recommended to prevent this. See Installation section.

Water in bottom of cabinet

1. Verify that pressure equalizing tubing is hooked up from top of electrode level canister to the tank.
2. Check steam distribution piping for obstructions.
3. Verify duct air velocity is less than 2000 FPM and manifold is not in a vertical down air flow.
4. Check for leaks at fittings and clamps in water supply lines.
5. Verify that tank access panel gasket is on lip of access hole and the access panel is secured tightly.
6. Make sure the duct pressure and steam distribution back pressure does not total more than 6" WC.

Diagnosics

There are some diagnostic routines programmed into the PC board. If these routines detect a problem the unit will shut down and display the error message on LCD, the "STATE" LED will be on in red.

1. **INIT: FILL TIME** - - The low level switch has not closed after 45 minutes of fill valve on time. This is only on initial start-up or after a complete drain down. **Check:** defective fill valve, debris in fill valve inlet screen or on tank drain screen, water leakage from tank or inlet tubing, no water flow or low water pressure, drain valve stuck open or leaking, defective low water level switch (electrodes need to be cleaned).
2. **UNABLE TO FILL** - - The low level switch has not closed after 10 minutes of fill valve on time. This is only after initial start-up fill and boil-down sequence. **Check:** debris in water switch canister, defective fill valve, no water flow or low water pressure, drain valve stuck open, defective low water level switch (electrodes need to be cleaned).
3. **WATER ABOVE HIGH LONGER** - - The high water switch is still closed 5 minutes after the fill valve has turned off upon hitting the high water level and a 1 minute drain does not drop the water below the high water level. **Check:** defective high water level switch, debris in level canister, fill valve stuck open, drain valve is defective or scale buildup in drain line.
4. **Invalid H₂O SW** - - The high level switch is closed and the low level switch is open. **Check:** defective level switch(es), debris in electrode level canister, scale on electrodes or canister, improper wiring of electrodes or float switches.
5. **HTR TEMP** - - Internal temperature exceeds safe level. **Check:** low water in tank, scale buildup on Thermocouple heating element surface, defective Thermocouple. See Clearing "Error" Codes section.
6. **NO LOW COND AFTER DRAIN** - - The low water level switch has not opened after a complete drain. Unit drains frequency and duration can be set in menu. **Check:** defective low water level switch or electrodes, defective drain valve, debris on low water level float switch or electrodes, tank drain screen, or in drain valve.
7. **LONGER FILL TO HI** - - The high water level switch has not closed 5 minutes after low level switch closed. **Check:** debris in fill valve inlet screen, water leaking from tank or inlet tubing, low water pressure, defective high water level switch (electrodes need to be cleaned).
8. **INIT: DRAIN TIME** - - The unit has not drained below the low water level probe on initial drain. **Check:** Defective low water level switch or electrodes, defective drain valve, debris on low water level float switch or electrodes, tank drain screen, or in drain valve.
9. **H₂O TEMP ERROR** - - Check aquastat connections at main board terminals 17 and 18.

Safety Switches

When the high limit or air proving (pressure) switch opens the state light will flash green and the message "Safety Open" will be shown on the front display. This is a soft error, it does not have to be reset. When the circuit closes the unit will go back to normal operation.

Typical Wiring Schematic

HC6100-Wye Wiring Layout (380V, 400V, 480V, 600V)

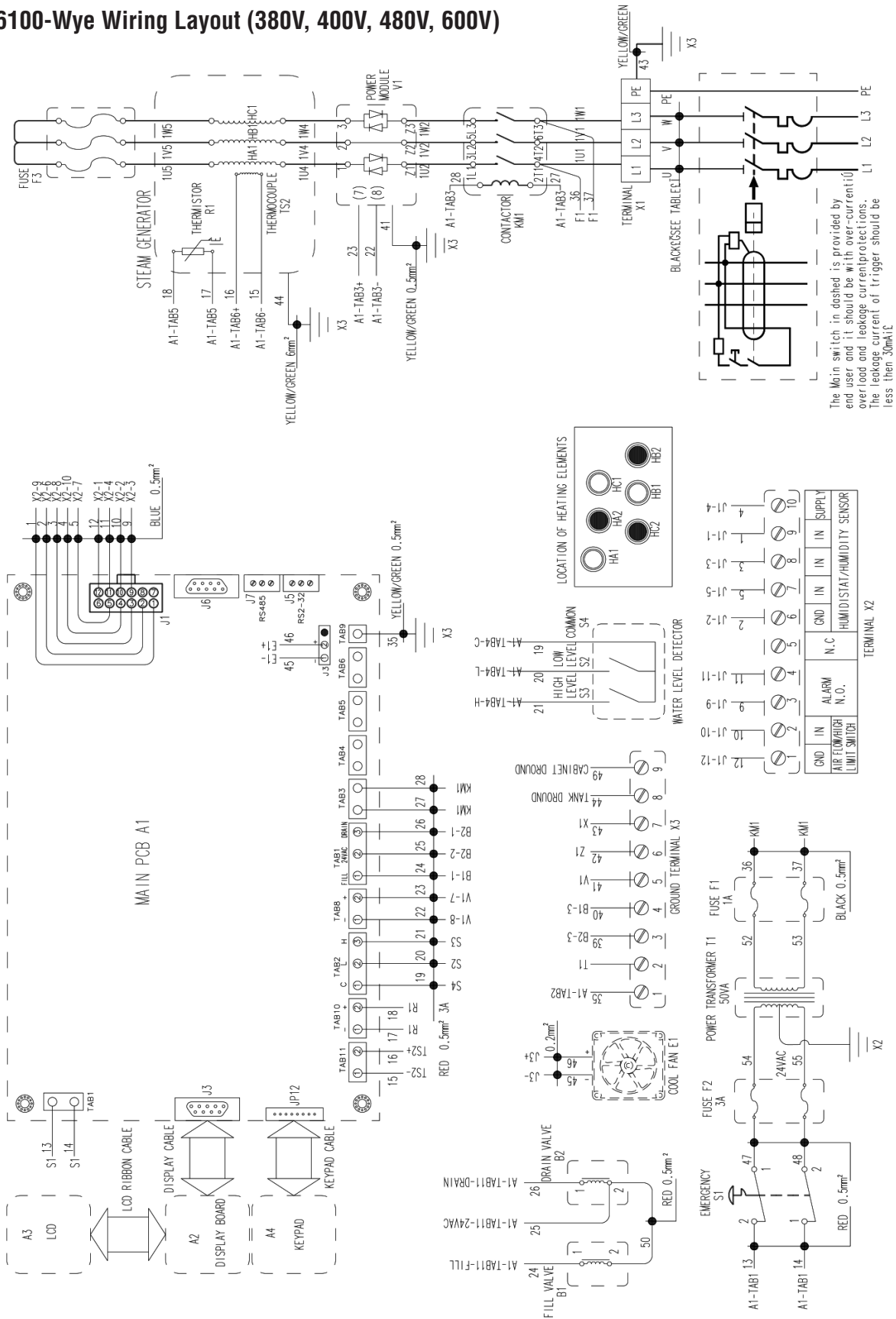

The Main switch in dashed is provided by end user and it should be with over-current/over load and leakage current protections. The leakage current of trigger should be less than 30mA.

HC6100-Delta Three Phase Wiring Layout (208V, 220V, 240V)

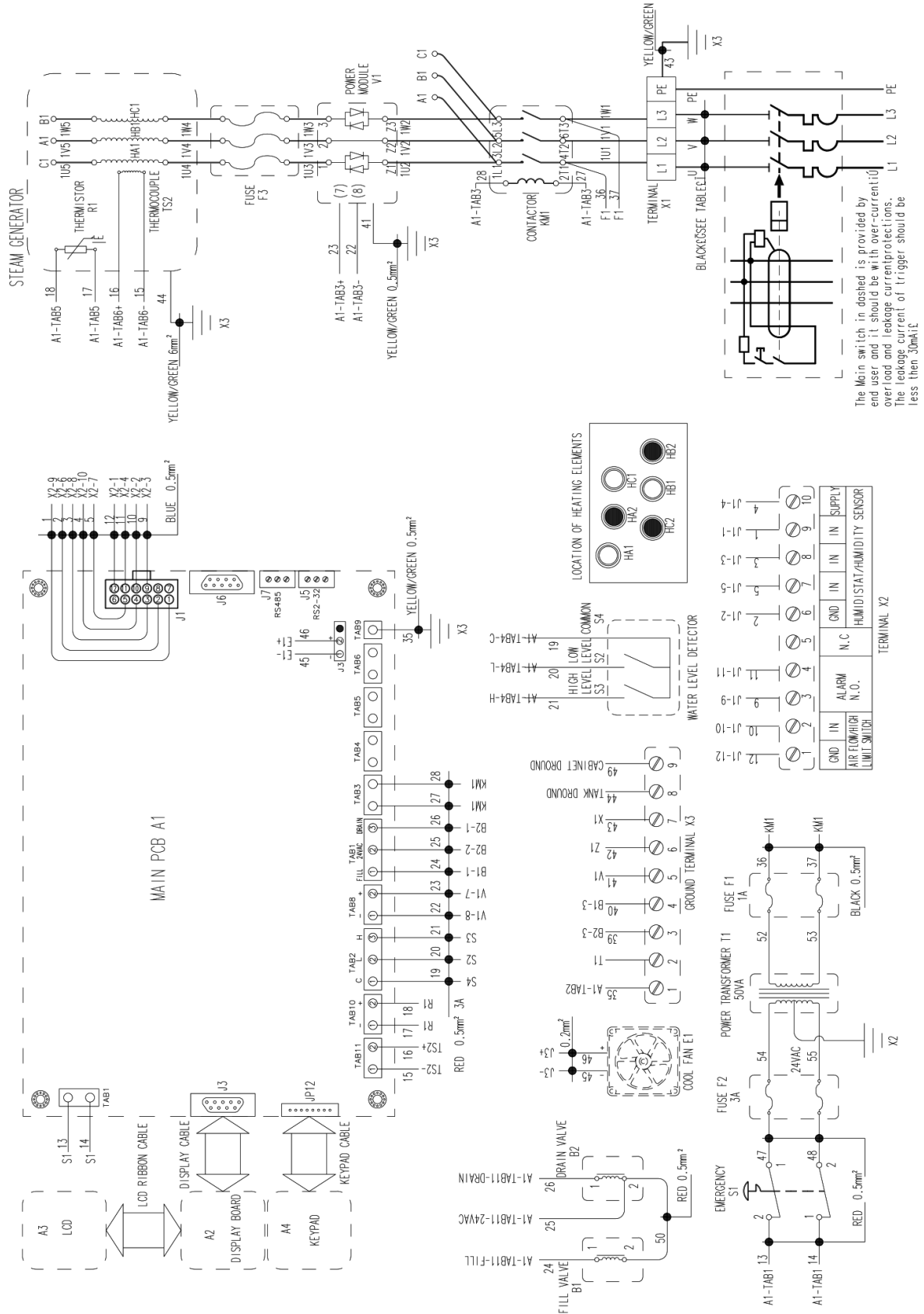

HC6300-Wye Wiring Layout (380V, 400V, 480V, 600V)

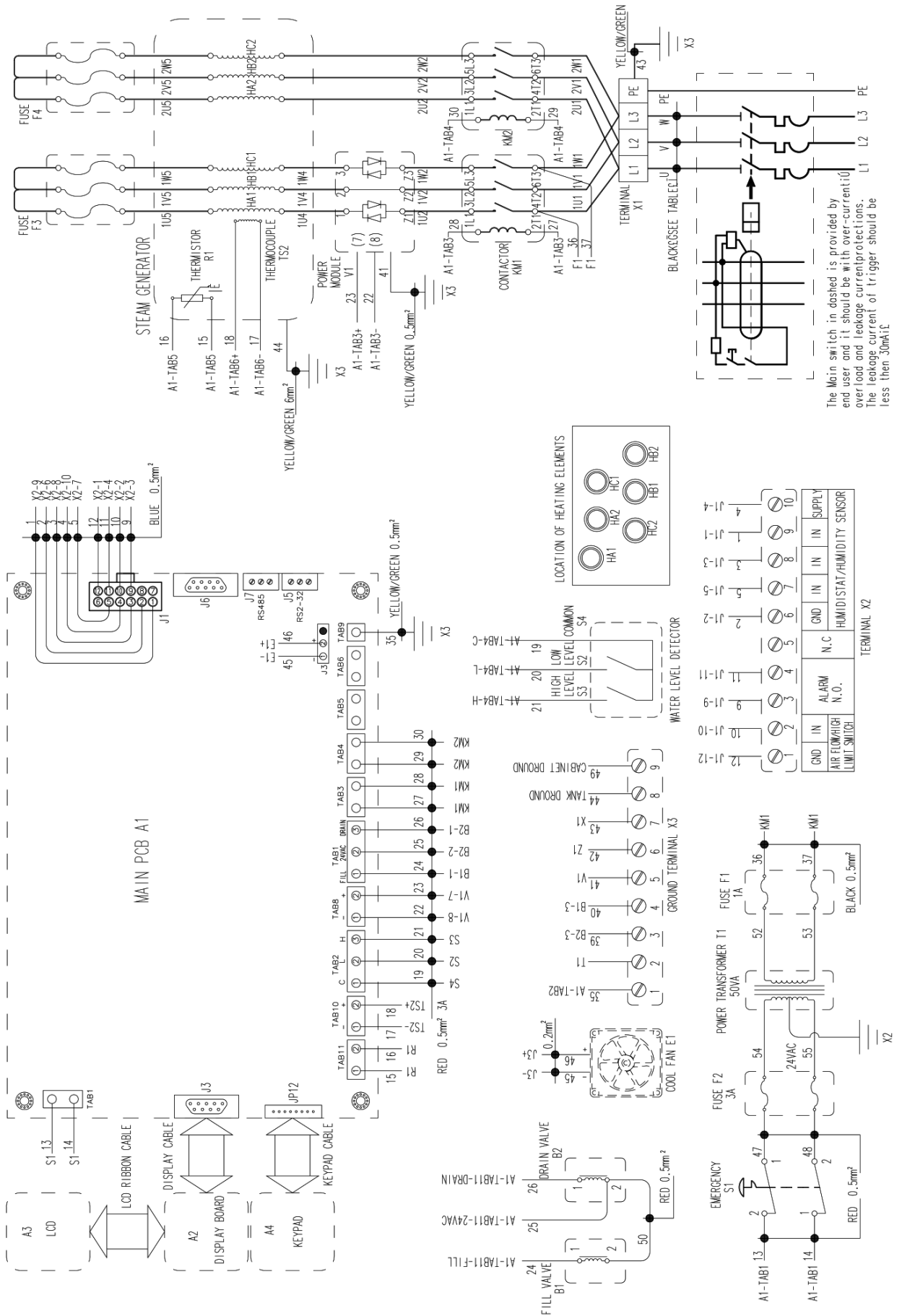

The Main switch in dashed is provided by end user and it should be with over-current, over load and leakage current protections. The leakage current of trigger should be less than 30mA.

HC6300-Delta Wiring Layout (208V, 220V, 240V)

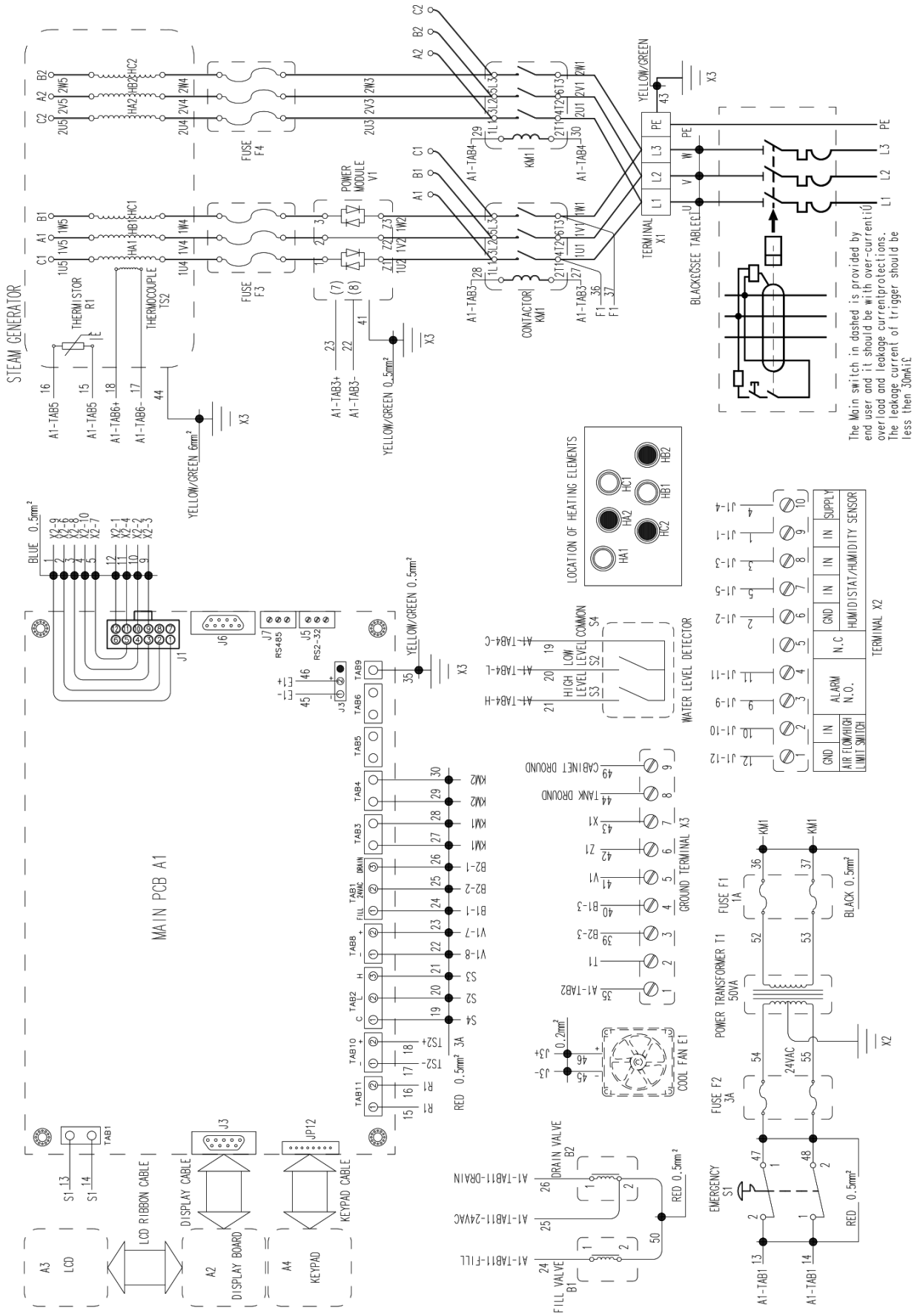

The Main switch in dashed line end user and it should be with over-current/overload and leakage current protections. The leakage current of trigger should be less than 30mAIE

HC6500-Delta Wiring Layout (208V, 220V, 240V)

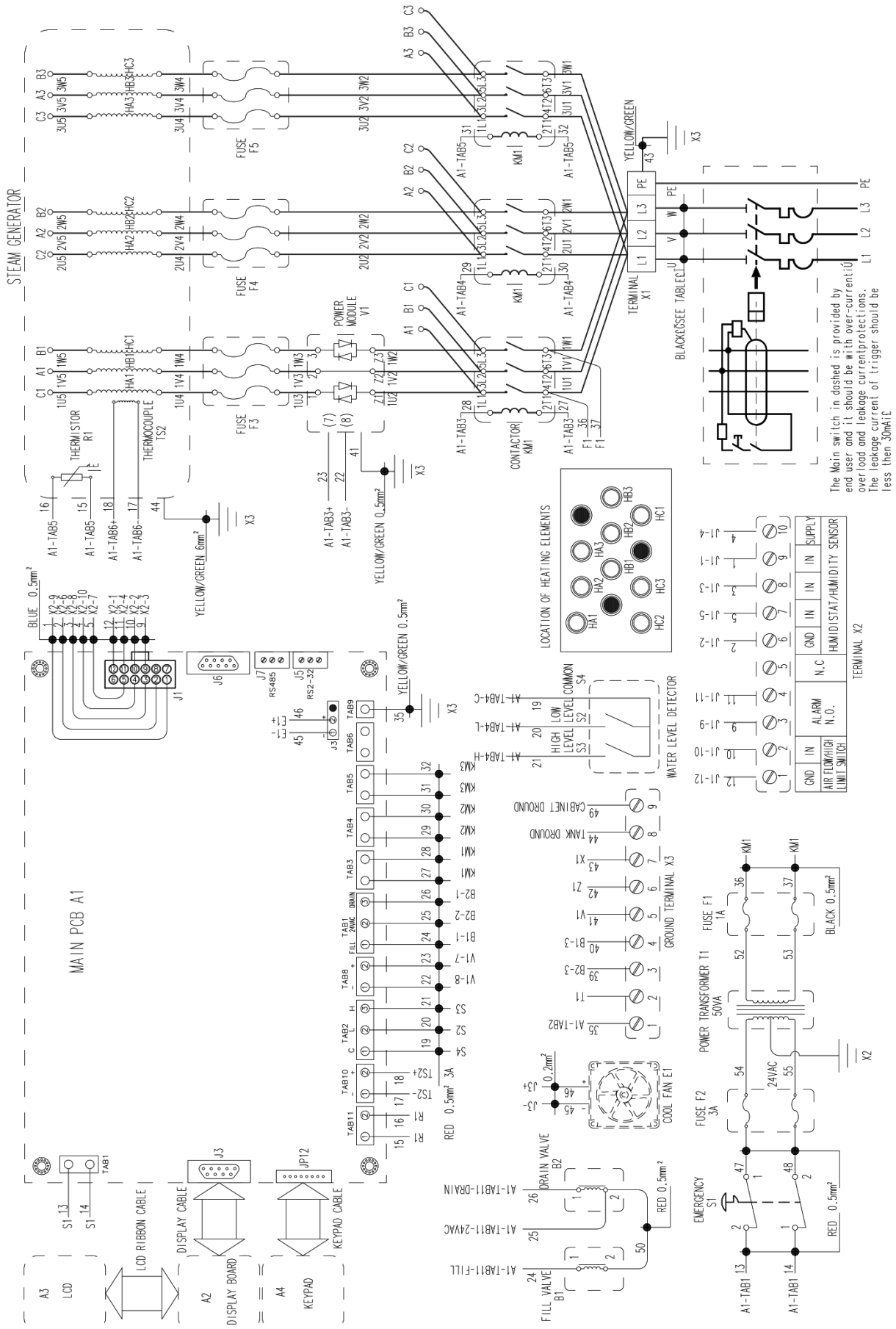

HC6500-WYE (2 contactors) Wiring Layout (380V, 400V, 480V, 600V)

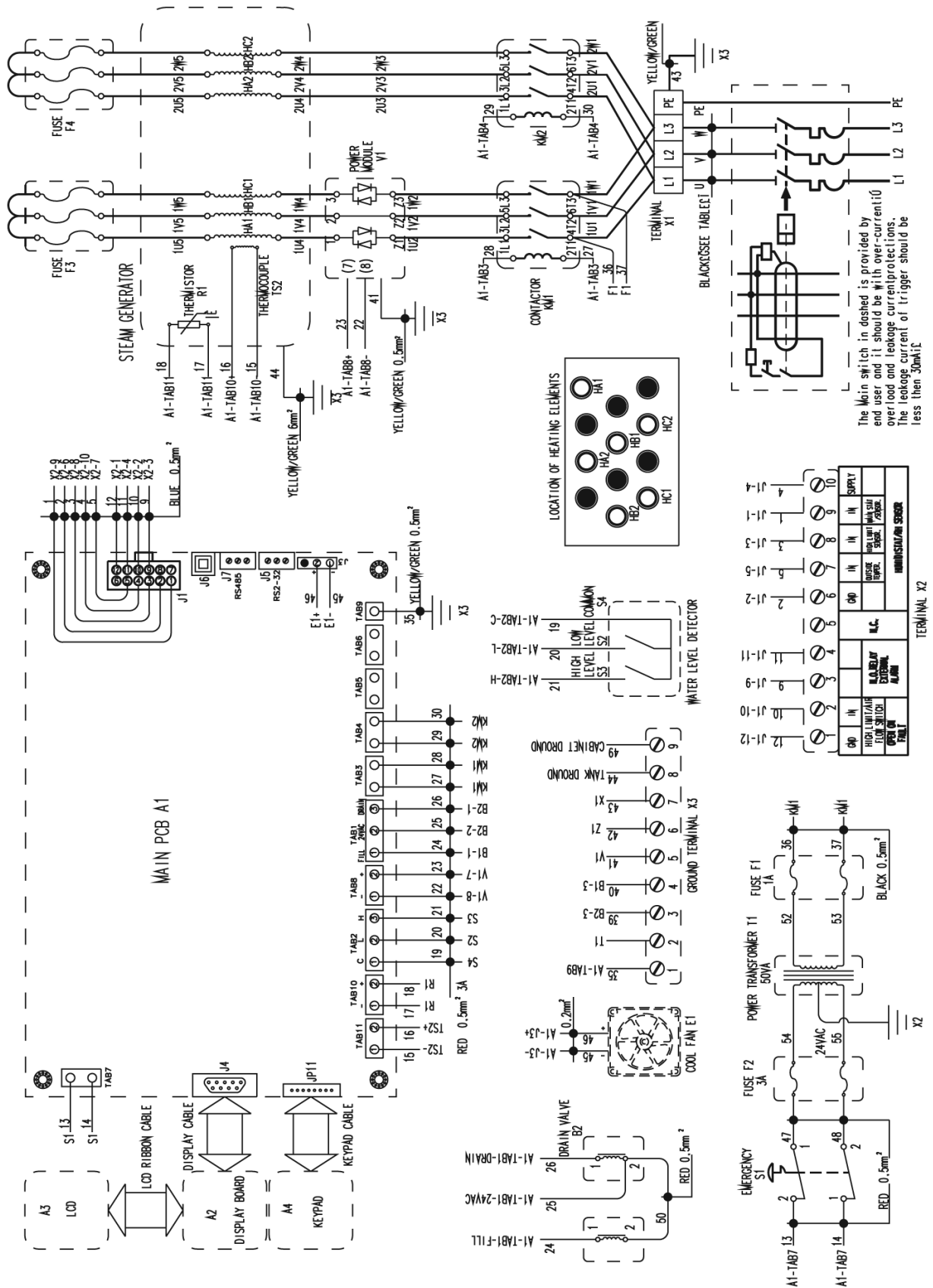

HC6500-Delta (2 contactors) Wiring Layout (208V, 220V, 240V)

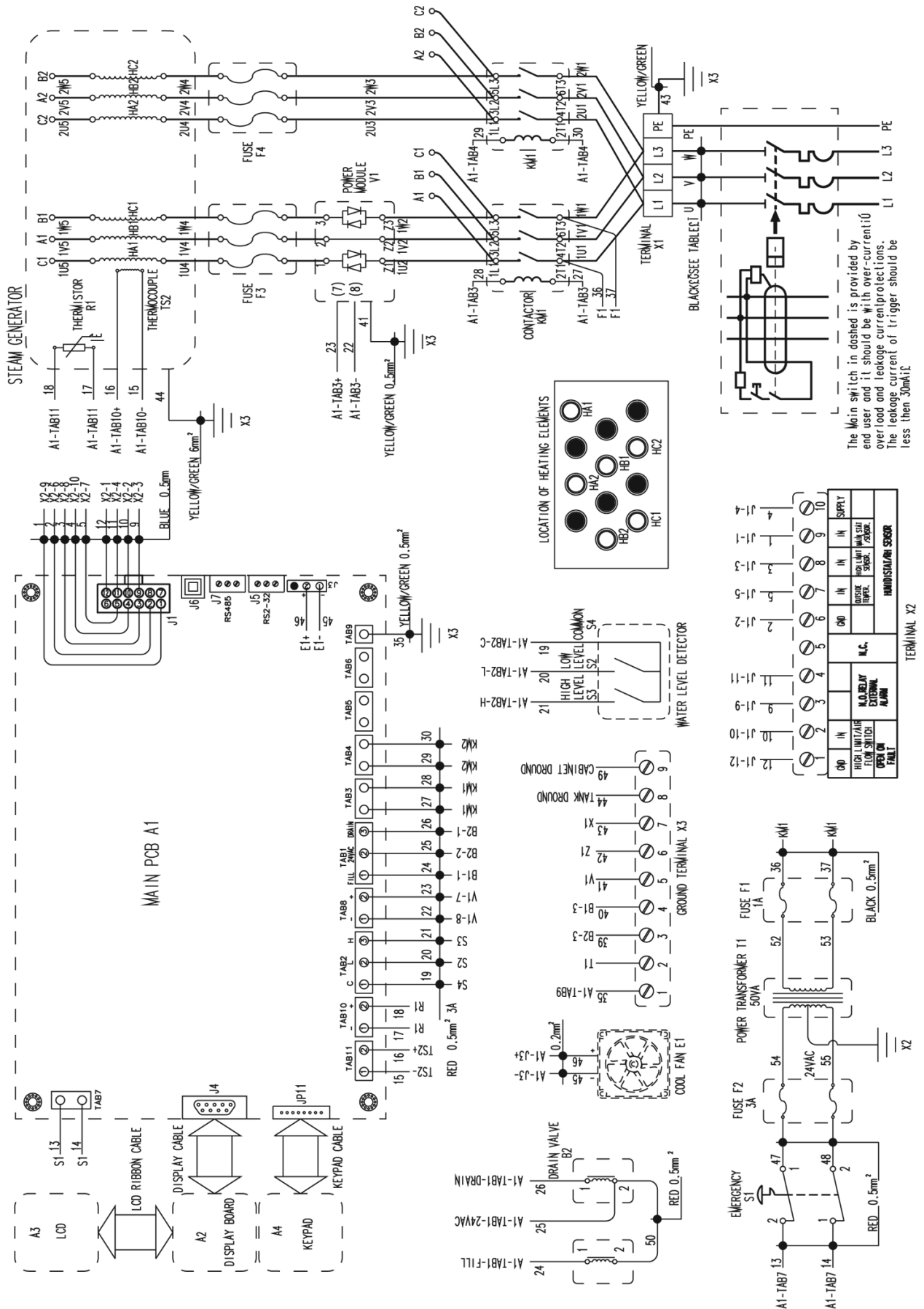

Repair Parts

HC6100/6300 Repair Parts

Item No.	Electrical Compartment and Front Panel	Part No.
31	Label Front Panel With Keypad	D10876
16	Emergency Stop Button	D10866
1	Main PCB For HC-6000	D56596
-	Wire Harness For HC-6500	D10874
-	Wire Harness For HC-6700	D10875
32a	LCD Display For HC-6000	D8024
32b	Display Driver Board	D56597
14	Fan DC24 with 2 Cover	D10869
12	Terminal Block #000 Wire	B5607
11	Definite-Purpose Contactor 50AMP	B2721
6	Fuse 3AMP	A10718
7	Fuse 1A	D11114
5	Fuse Block 3AMP	A8649
13	Module Power Din 15KW HC-6000	B5092
13	Module Power Din 15KW HC-6000	B5151
8	Trans 208/240/380/480-24V	B5605
8	Trans 600V-24V	B5604
3	Fuse Holder 30 AMP HC-6000	B4039
3	Fuse Holder 30 AMP HC-6000	A21882
4	Fuse 30 AMP HC-6000	B4040
4	Fuse 40 AMP HC-6000	A21883
4	Fuse 50 AMP HC-6000	A21884

Item No.	Water Compartment	Part No.
-	PVC Tubing 5/8"	A7618A
-	Clap Hose Flat .63 Olive	B2716-11
-	Hose Clamp, Minerature, Worm	B2911-8
25	Fill Valve	D10867
25	Fill Valve SS DI/RO	D10721
21	Tubing Rd 7/8 Old Silicon	A19699
23	Clamp Hose Flat .88	B2716-18
22	Tee Barbed HDPE 5/8	A23237
24	Elbow Barbed 5/8	A10579
27	Fill Cup For Series HC-6000	RDHC6000-001
27	Bracket For Fill Cup	B2929
28	Bracket Liquid Level	B5135
28	Brkt HC-6000 Liquid Level	A22010
20	Drain Valve	D10868
18	Drain Cup	D10862
17	Reducing Bushing Brass 1"-1/2"	D11443
30	Probe Level Assy Tap	C4561
29	Container For Probe Level	C4559
-	Long Probe For Water Level (Low and Common)	B5268
-	Short Probe For Water Level (High)	B5269
-	Reducing Bushing For Water Level	A21391
-	Float Level Assy DI/RO	C4560
-	Float Switch DI/RO	B5139
Item No.	Water Compartment	Part No.
26	S-assy Ionic Bed HC-6000 (14 required for Model HC-6500 and HC-6700)	B5213
-	Thermistor 5 KOHM With Wire (Aquistat)	D10870

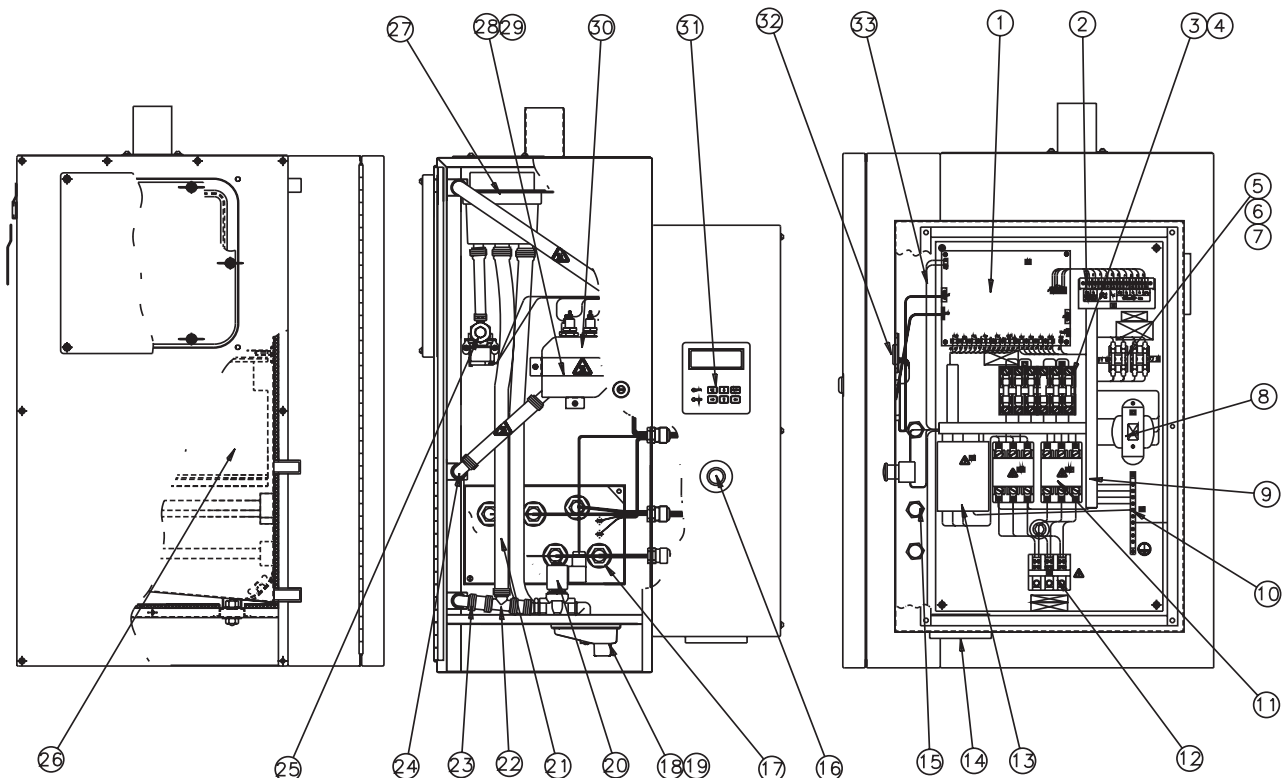

Heating Elements 6100/6300

TC= Thermocouple

HC-6100				
Voltage	3kW		3kW DI	
	Without TC 2PCS/Unit	With TC 1PCS/Unit	Without TC 2PCS/Unit	With TC 1PCS/Unit
208	B5808-1	B5809-1	B5810-1	B5811-1
240	B5808-2	B5809-2	B5810-2	B5811-2
380	B5808-1	B5809-1	B5810-1	B5811-1
480	B5808-3	B5809-3	B5810-3	B5811-3
600	B5808-4	B5809-4	B5810-4	B5811-4
HC-6100				
Voltage	9kW		15kW	
	Without TC 2PCS/Unit	With TC 1PCS/Unit	Without TC 2PCS/Unit	With TC 1PCS/Unit
208	B5047-1	B5048-1	B5043-1	B5044-1
240	B5047-2	B5048-2	B5043-2	B5044-2
380	B5047-1	B5048-1	B5043-1	B5044-1
480	B5047-3	B5048-3	B5043-3	B5044-3
600	B5047-4	B5048-4	B5043-4	B5044-4
HC-6100 DI				
Voltage	9kW		15kW	
	Without TC 2PCS/Unit	With TC 1PCS/Unit	Without TC 2PCS/Unit	With TC 1PCS/Unit
208	B5049-1	B5050-1	B5045-1	B5046-1
240	B5049-2	B5050-2	B5045-2	B5046-2
380	B5049-1	B5050-1	B5045-1	B5046-1
480	B5049-3	B5050-3	B5045-3	B5046-3
600	B5049-4	B5050-4	B5045-4	B5046-4
HC-6300				
Voltage	18kW		30kW	
	Without TC 5PCS/Unit	With TC 1PCS/Unit	Without TC 5PCS/Unit	With TC 1PCS/Unit
208	B5047-1	B5048-1	B5043-1	B5044-1
240	B5047-2	B5048-2	B5043-2	B5044-2
380	B5047-1	B5048-1	B5043-1	B5044-1
480	B5047-3	B5048-3	B5043-3	B5044-3
600	B5047-4	B5048-4	B5043-4	B5044-4
HC-6300 DI				
Voltage	18kW		30kW	
	Without TC 5PCS/Unit	With TC 1PCS/Unit	Without TC 5PCS/Unit	With TC 1PCS/Unit
208	B5049-1	B5050-1	B5045-1	B5046-1
240	B5049-2	B5050-2	B5045-2	B5046-2
380	B5049-1	B5050-1	B5045-1	B5046-1
480	B5049-3	B5050-3	B5045-3	B5046-3
600	B5049-4	B5050-4	B5045-4	B5046-4

HC6500/6700 Repair Parts

Item No.	Electrical Compartment and Front Panel	Part No.
31	Label Front Panel With Keypad	D10876
16	Emergency Stop Button	D10866
1	Main PCB For HC-6000	D56596
-	Wire Harness For HC-6500	D10874
-	Wire Harness For HC-6700	D10875
32a	LCD Display For HC-6000	D8024
32b	Display Driver Board	D56597
14	Fan DC24 with 2 Cover	D10869
12	Terminal Block #000 Wire	B5607
11	Definite-Purpose Contactor 50AMP	B2721
6	Fuse 3AMP	A10718
7	Fuse 1A	D11114
5	Fuse Block 3AMP	A8649
13	Module Power Din 15KW HC-6000	B5092
13	Module Power Din 15KW HC-6000	B5151
8	Trans 208/240/380/480-24V	B5605
8	Trans 600V-24V	B5604
3	Fuse Holder 30 AMP HC-6000	B4039
3	Fuse Holder 30 AMP HC-6000	A21882
4	Fuse 30 AMP HC-6000	B4040
4	Fuse 40 AMP HC-6000	A21883
4	Fuse 50 AMP HC-6000	A21884

Item No.	Water Compartment	Part No.
-	PVC Tubing 5/8"	A7618A
-	Clap Hose Flat .63 Olive	B2716-11
-	Hose Clamp, Minerature, Worm	B2911-8
25	Fill Valve	D10867
25	Fill Valve SS DI/RO	D10721
21	Tubing Rd 7/8 Old Silicon	A19699
23	Clamp Hose Flat .88	B2716-18
22	Tee Barbed HDPE 5/8	A23237
24	Elbow Barbed 5/8	A10579
27	Fill Cup For Series HC-6000	RDHC6000-001
27	Bracket For Fill Cup	B2929
28	Bracket Liquid Level	B5135
28	Brkt HC-6000 Liquid Level	A22010
20	Drain Valve	D10868
18	Drain Cup	D10862
17	Reducing Bushing Brass 1"-1/2"	D11443
30	Probe Level Assy Tap	C4561
29	Container For Probe Level	C4559
-	Long Probe For Water Level (Low and Common)	B5268
-	Short Probe For Water Level (High)	B5269
-	Reducing Bushing For Water Level	A21391
-	Float Level Assy DI/RO	C4560
-	Float Switch DI/RO	B5139
Item No.	Water Compartment	Part No.
26	S-assy Ionic Bed HC-6000 (14 required for Model HC-6500 and HC-6700)	B5213
-	Thermistor 5 KOHM With Wire (Aquastat)	D10870

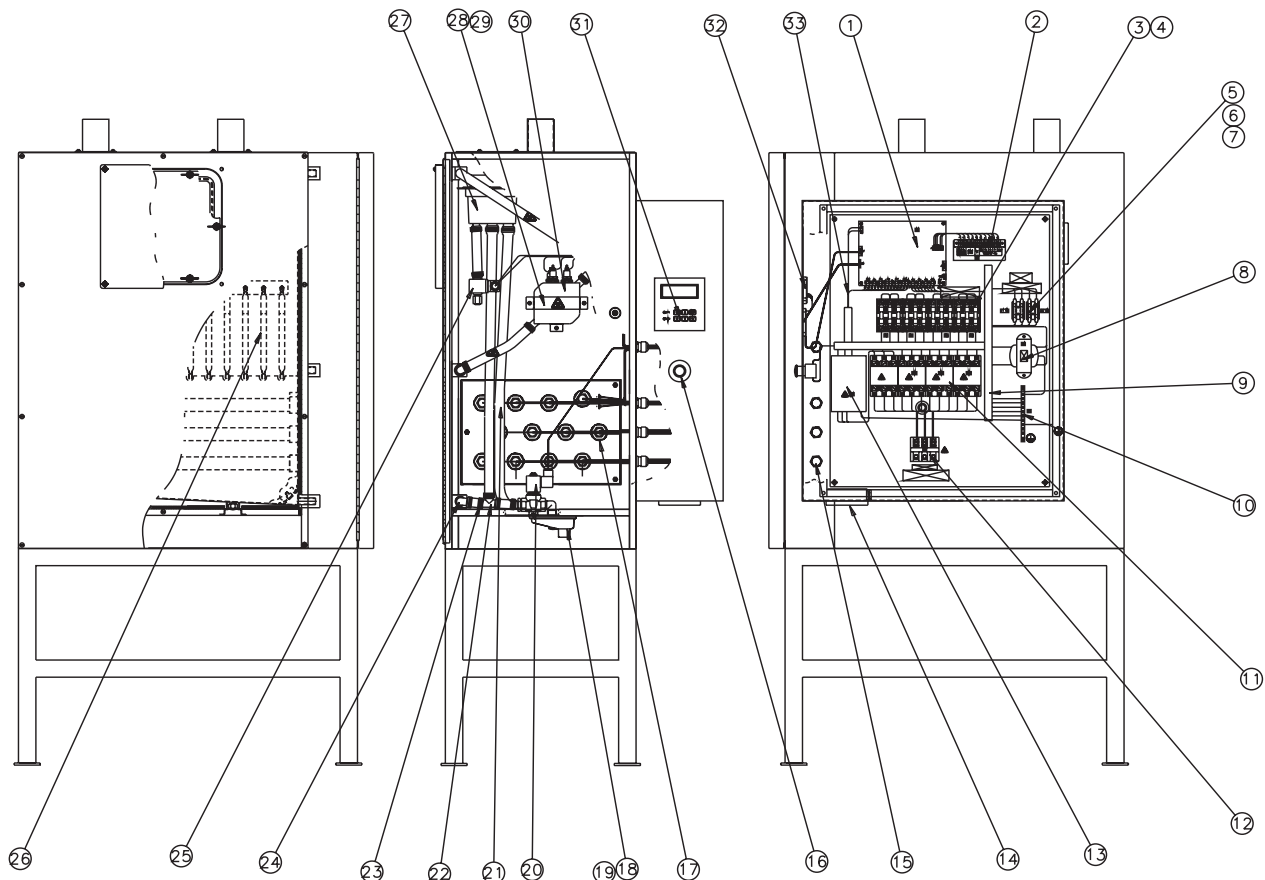

Heating Elements 6500/6700

TC= Thermocouple

HC6500/HC6700										
Voltage	30kW		33.5kW		40kW		45kW			
	Without TC 5PCS/Unit	With TC 1PCS/Unit	Without TC 5PCS/Unit	With TC 1PCS/Unit	Without TC 5PCS/Unit	With TC 1PCS/Unit	Without TC 8PCS/Unit	With TC 1PCS/Unit		
208	B5433-1	B5434-1	-	-	-	-	B5433-1	B5434-1	B5433-1	B5434-1
240	-	-	-	-	B5433-1	B5434-1	-	-	-	-
380	-	-	B5433-1	B5434-1	-	-	-	-	-	-
480	-	-	-	-	-	-	-	-	-	-
600	-	-	-	-	-	-	-	-	-	-

HC6500/HC6700										
Voltage	48kW		50.3kW		60kW		72kW		96kW	
	Without TC 5PCS/Unit	WithTC 1PCS/Unit	Without TC 8PCS/Unit	WithTC 1PCS/Unit	Without TC 8PCS/Unit	WithTC 1PCS/Unit	Without TC 8PCS/Unit	WithTC 1PCS/Unit	Without TC 11PCS/Unit	WithTC 1PCS/Unit
208	-	-	-	-	-	-	-	-	-	-
240	-	-	-	-	B5437-1	B5438-1	-	-	-	-
380	B5437-1	B5438-1	B5437-1	B5438-1	-	-	B5437-1	B5438-1	B5437-1	B5438-1
480	B5437-2	B5438-2	-	-	-	-	B5437-2	B5438-2	B5437-2	B5438-2
600	B5437-3	B5438-3	-	-	-	-	B5437-3	B5438-3	B5437-3	B5438-3

HC6500/HC6700 DI										
Voltage	30kW		33.5kW		40kW		45kW			
	Without TC 5PCS/Unit	WithTC 1PCS/Unit	Without TC 5PCS/Unit	WithTC 1PCS/Unit	Without TC 5PCS/Unit	WithTC 1PCS/Unit	Without TC 8PCS/Unit	WithTC 1PCS/Unit		
208	B5435-1	B5436-1	-	-	-	-	B5435-1	B5436-1	B5435-1	B5436-1
240	-	-	-	-	B5435-1	B5436-1	-	-	-	-
380	-	-	B5435-1	B5436-1	-	-	-	-	-	-
480	-	-	-	-	-	-	-	-	-	-
600	-	-	-	-	-	-	-	-	-	-

HC5600/HC6700 DI										
Voltage	48kW		50.3kW		60kW		72kW		96kW	
	Without TC 5PCS/Unit	WithTC 1PCS/Unit	Without TC 8PCS/Unit	WithTC 1PCS/Unit	Without TC 8PCS/Unit	WithTC 1PCS/Unit	Without TC 8PCS/Unit	WithTC 1PCS/Unit	Without TC 11PCS/Unit	WithTC 1PCS/Unit
208	-	-	-	-	-	-	-	-	-	-
240	-	-	-	-	B5439-1	B5440-1	-	-	-	-
380	B5439-1	B5440-1	B5439-1	B5440-1	-	-	B5439-1	B5440-1	B5439-1	B5440-1
480	B5439-2	B5440-2	-	-	-	-	B5439-2	B5440-2	B5439-2	B5440-2
600	B5439-3	B5440-3	-	-	-	-	B5439-3	B5440-3	B5439-3	B5440-3

Resistance Values of Components

Resistance Value of 6100/6300 Components		
Component	Voltage	Resistance
Fill Valve	24Vac	18Ω
Drain Valve	24Vac	10Ω
Contractor	24Vac	7-9Ω
Thermocouple in Heating Elements	-	0.51Ω
Heating Elements		
208Vac and 380Vac 3kW	220Vac	46.0-48.6Ω
240Vac and 380Vac 3kW	240Vac	55-58Ω
480Vac and 380Vac 3kW	277Vac	72-78.2Ω
600Vac and 380Vac 3kW	346 Vac	112.4-122.4Ω
208Vac and 380Vac15/30kW	220Vac	9.2-10.7Ω
240Vac 15/30kW	240Vac	10.9-12.6Ω
480Vac 15/30kW	277Vac	14.5-16.8Ω
600Vac 15/30kW	346Vac	22.7-26.3Ω
208Vac and 380Vac9/18kW	220Vac	15.3-17.7Ω
240Vac 9/18kW	240Vac	18.2-21.1Ω
480Vac 9/18kW	277Vac	24.3-28.2Ω
600Vac 9/18kW	346Vac	37.9-43.9Ω
Power Transformer	120Vac	13.6Ω across H1-H2 15.1Ω across H3-H4
	208Vac	22Ω across H1-H2
	240Vac	29Ω across H1-H2
	380Vac	77Ω across H1-H2
	480Vac	125Ω across H1-H2
600Vac	194Ω across H1-H2	
Power Transformer (secondary)	All Voltage	0.6Ω across X1-X2 0.4Ω across X1-X2

Resistance Value of 6500/6700 Components		
Component	Voltage	Resistance
Fill Valve	24Vac	8.8Ω
Drain Valve	24Vac	4.1Ω
Thermocouple in Heating Elements	-	0.51Ω
Heating Elements		
208, 240, 380V, 30/33, 5/40/45/50, 3/60kW	240Vac	7.4-9.1Ω
380V 48/72/96kW	220Vac	5.2-6.3Ω
480V 48/72/96kW	277Vac	8.1-10.0Ω
600V 48/72/96kW	346 Vac	12.8-15.7Ω
Power Transformer		
Primary Loop	208Vac	18Ω across H1-H2
	240Vac	21Ω across H1-H3
	277Vac	24Ω across H1-H4
	380Vac	40Ω across H1-H5
	480Vac	22Ω across H1-H6
Secondary Loop	600Vac	22Ω across H1-H2
	208Vac	1Ω across X1-X2
	240Vac	1Ω across X1-X2
	277Vac	1Ω across X1-X2
	380Vac	1Ω across X1-X2
480Vac	1Ω across X1-X2	
600Vac	1Ω across X1-X2	

Note: All measurements should be made with the main power off and the wires to the component being tested disconnected.

PID Control

PID control is essential on the HumidiClean™ series for maintaining the desired relative humidity (RH) by adjusting the humidifiers output. Please note that the PID control is only used when a RH sensor is supplying the demand in place of a humidistat (configured in Operation Setup Menu). The PID Settings will control how the demand is adjusted according to the error between the current RH and the desired RH set point. There are four variables of the PID control that can be adjusted to customize the way your HumidiClean™ reacts to a demand signal.

Proportional Band (PB) – The proportional band value determines how your humidifier will react to the current error (desired – current). Larger PB values will take longer for your unit to reach its RH set point. Smaller PB values will quickly reach their RH set points but possibly result in demand instability (demand bounces between on and off). The default PB value on the HumidiClean™ is 15.

Integral Reset Value (IRV) – Values above 30 are not recommended due to instability. The integral reset value determines how your humidifier will react to the sum of the amount of error in the past. By decreasing the IRV, you will have less overshoot after you reach your RH set point, but increase the amount of time it takes to reach the set point. Increasing your IRV will allow you to quickly achieve your RH set point and reach a steady demand, but will have higher RH overshoot in the process. The default IRV value on the HumidiClean™ is 125.

Derivative Gain (DG) – The derivative gain value determines how much your demand will be affected by the past rate of change of error on your HumidiClean™. Larger DG values will improve the demand stability and decrease RH overshoot near the RH set point. However, larger DG values can also amplify any noise in the demand signal between the controller and the HumidiClean™, giving the unit an unstable demand. The default DG value on the HumidiClean™ is 0.

SI Interval (SI) – The SI interval value controls how much data from the past is used for calculating the integral term and derivative term. The SI interval value is in seconds, so the default SI interval value of 10 means 10 seconds of past error data is used when calculating the integral and derivative terms.

Shortcuts to tuning your PID values – If your HumidiClean™:

- **is not reaching its desired RH quick enough**, decrease the proportional band (PB) value or integral reset value (IRV) slowly until acceptable rate is reached. Increasing both of these values will help you reach your desired RH value quicker. Caution, decreasing your PB value too low can create an unstable demand scenario when your demand will bounce between having a demand and zero, causing your contactor to pull in and out constantly. Avoid this by slowly decreasing your PB value in increments so the value does not create instability. Increasing your IRV value too high will result in higher overshoot, causing your %RH to rise above the desired %RH (higher IRV values create higher overshoot).
- **has too high of an overshoot**, decrease the integral reset value (IRV) or increase the derivative gain (DG) slowly until acceptable overshoot is found. Decreasing the IRV will decrease your overshoot, but it will also increase the time it takes for your humidifier to reach its desired RH. Increasing your DG value will help improve demand stability (reaching a constant demand value) and decrease set point overshoot, but could amplify any signal noise (if there is any) coming from your RH sensor. Amplifying signal noise could create an unstable demand and create a false demand (humidifying when there is no need).
- **has an unstable demand** (contactor pulling in and out), decrease your proportional band (PB) value or increase your derivative gain (DG) value. Increasing your PB value will help reach a stable demand, but it will increase the time it takes to reach the desired RH. Another solution to fixing an unstable demand is to increase the DG value. However, if you have any noise in your demand signal, increasing the DG value will only make your unit demand act worse. If this is the case you should decrease the DG value.

Software Update

Procedure of HC6000 PCB-1 R1.2/1.3 Board Soft Refresh

Install the driver program for Atmel MCU, SAM-BA on your computer first. The link for the latest version of the Atmel program can be found here: www.armstronginternational.com/hc6000refresh

- Before refreshing the code, the old code in CPU must be erased:
 1. Turn off the power supply from the breaker, and push the emergency stop button in.
 2. Put berg jumper S4 on pins 1 and 2, turn on the breaker and pull out emergency button. The indicator LED D47 on main board will remain ON. Keep the power supply on for at least 10 seconds. (This is the step to erase the old code.)
 3. Turn off the power supply and put the berg jumper S4 on pins 2 and 4.
 4. Turn on the power supply, the indicator LED D47 will remain ON.
- Loading the new code:
 5. Connect the main board to computer with an USB cable. The computer should find the new hardware, “ATMEL AT91xxxx Test Board “and install driver for board automatically.
If system can not find the board automatically, please install driver manual, the path of the install file .inf is:
C:\Program Files (x86)\Atmel\sam-ba_2.15\drv
 6. Run program SAM-BA select the connection port as “\usb\ARM0”, select board as “at91sam3s4-ek”, please see Figure 43-1.

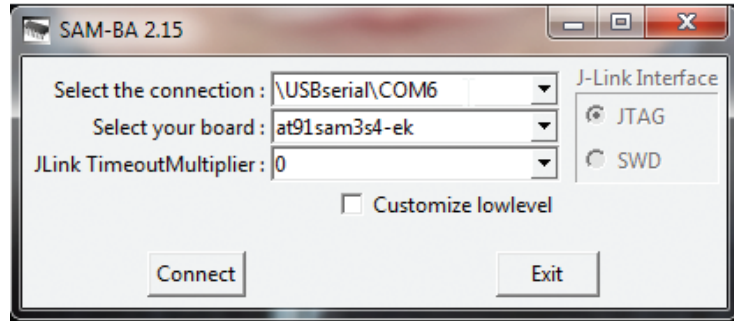

Fig. 43-1 SAM-BA Start Up Window

7. Click “Connect” button to enter the download window. Please see Figure 44-1.

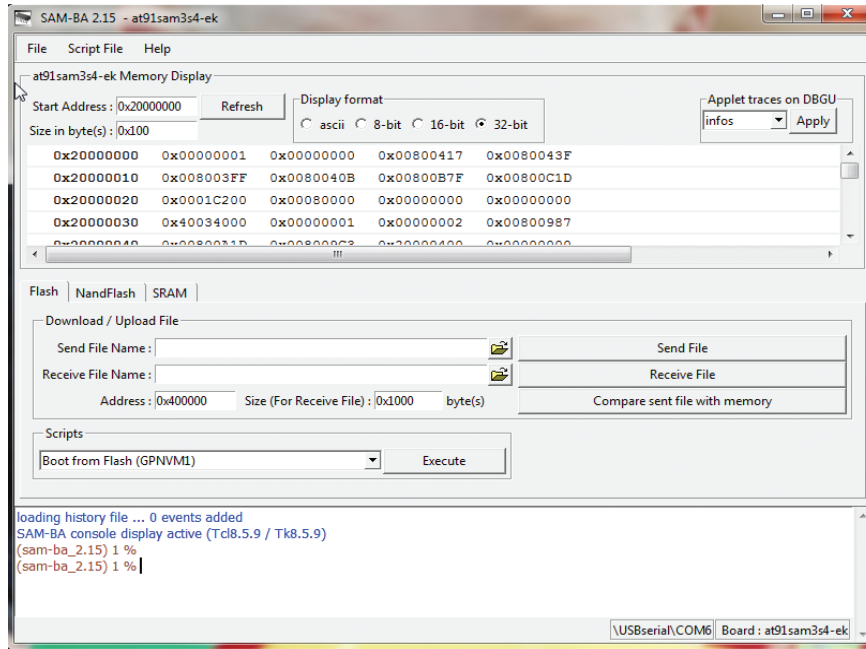

Fig. 44-1 Code Download Window

8. Click the “open folder” button on the right of textbox “Send File Name” to open the latest code, please see Figure 44-2. You will then have to locate the .bin file that you downloaded from the website and then hit open.

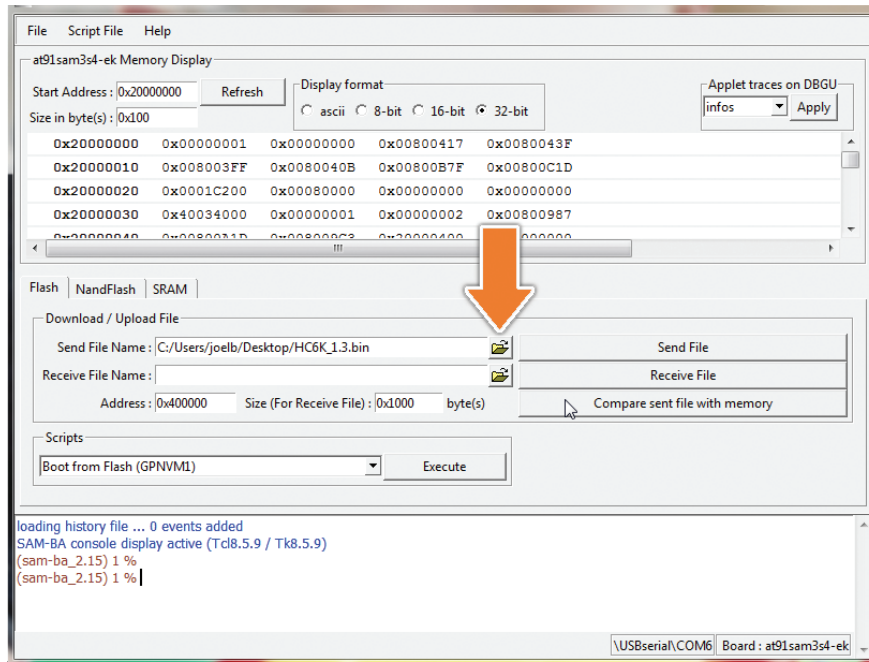

Fig. 44-2 Open the Latest Code Window

- Click the button “Send File” to send the latest code into board. You will be asked to unlock the involved lock regions (0 to 6), click the button “Yes” to begin send code into board. Please see Figure 45-1.

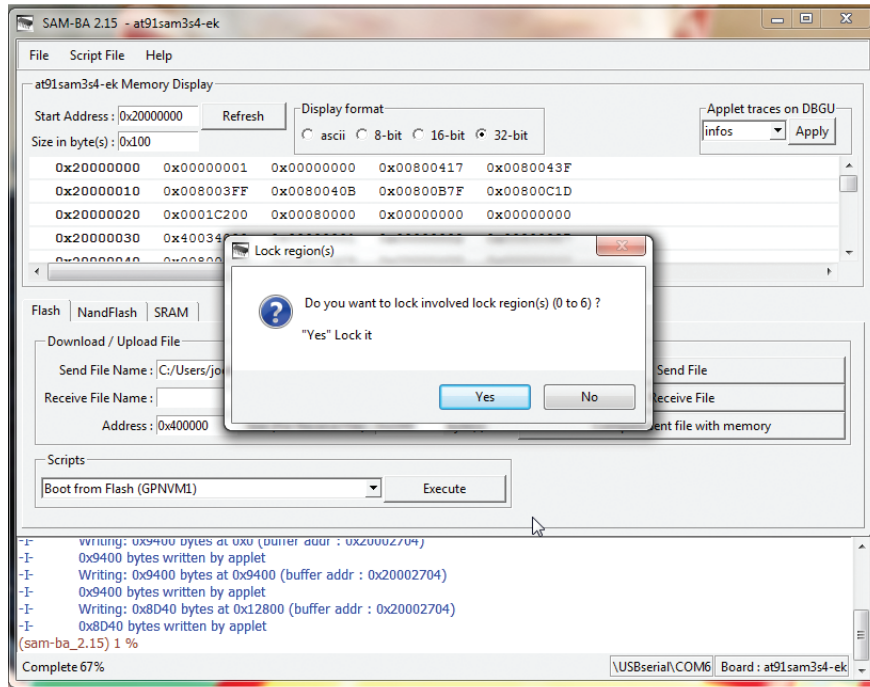

Fig. 45-1 Message Unlock Involved Lock Regions Window

- When sending has finished press the Execute button. See Figure 45-2.

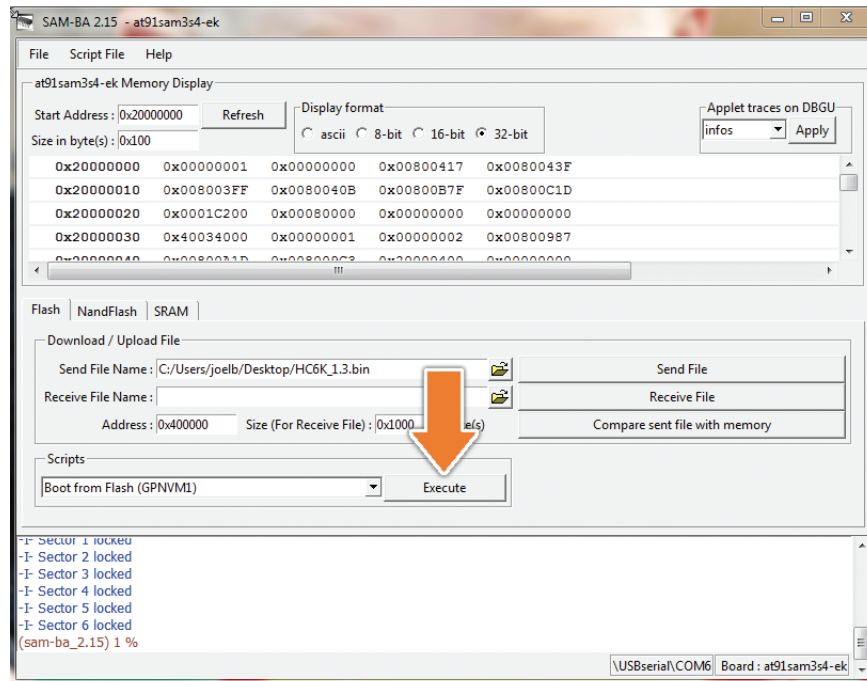

Fig. 45-2 Press the Execute Button

- When operation has finished, close the “SAM-BA” window first, and then click the icon “remove the USB hardware” to disconnect the link between computer and board. After reminder by system, disconnect the power supply from breaker and pull out the USB cable.
- The soft refresh of HC-6000 is complete restart the unit.

Communication

Modbus Protocol Setup

- 1) Wire to the RS-485 port, following Figure 46-1.
- 2) Make sure that all proper connections are made and that the installation instructions that start on page 6 have been adhered to. Power unit on.
- 3) Once unit is on go to “Setup” and verify the following data:
 - a. Network Control –
 - i. Monitor, Hstat, Sensor or Full
 - b. Comm Address – Default is 1, but set to fit your system
(If using multiple units, each unit should have a different Secondary ID)
 - c. Network Mode – Modbus
(When the screen shows Modbus hit enter to go to advanced settings)
 - i. Baud Rate – Default is 9600, but set to match your system
 - ii. Parity – Default is Even Parity, but set to match your system
- 4) Now the changes to the actual unit are complete use Table 46-1 Modbus Variants List to help set up the required points in the Building Management System.

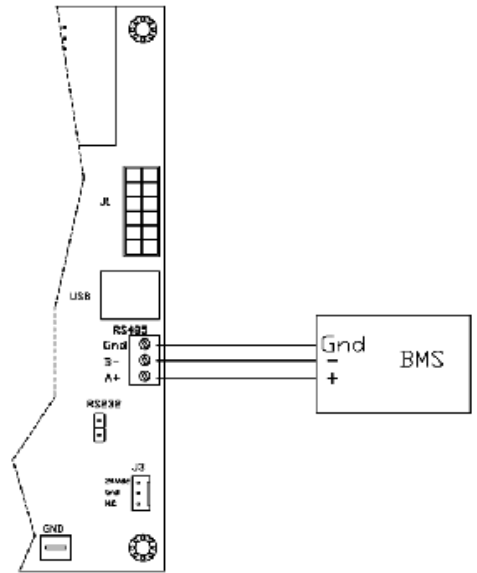

Figure 46-1. Modbus RS485 Wiring

LonWorks™ Protocol Setup

- 1) Attach protocontroller into upper right hand corner of main pc board. The ethernet connection should be going to the inside of the board. (See Figure 46-1) Make sure that all pins are seated properly and making a good connection.
- 2) Land two-wire BMS system to wire terminal on protocontroller. (See Figure 46-1)
- 3) Make sure that all proper connections are made and that the installation instructions that start on page 6 have been adhered to. Power unit on.
- 4) When the humidifier is powered access the Setup menu through the front display and set the following information:
 - a. Network Mode – PSP
 - b. Comm Address - 1
- 5) Now the changes to the actual unit are complete use Table 49-1 LonWorks™ Variants List to help set up the required points in the Building Management System. The .xif file is available and can be extracted from the protocontroller using an Ethernet cable. See the instructions “accessing the Protocontroller via the IP connection”.
- 6) A few minutes after the unit is powered on the Initialization LED should light. The protocontroller will not communicate until this LED is illuminated.
- 7) When the Lon device is commissioned the Lon LED on the protocontroller will stop blinking and will be on solid.
- 8) The device should be communicating.
- 9) After any permanent changes are made to the variables on the BMS side these should be saved at the unit as well to set them as defaults. This can be done by going in to the Operation Setup menu in the “Save Settings” screen.

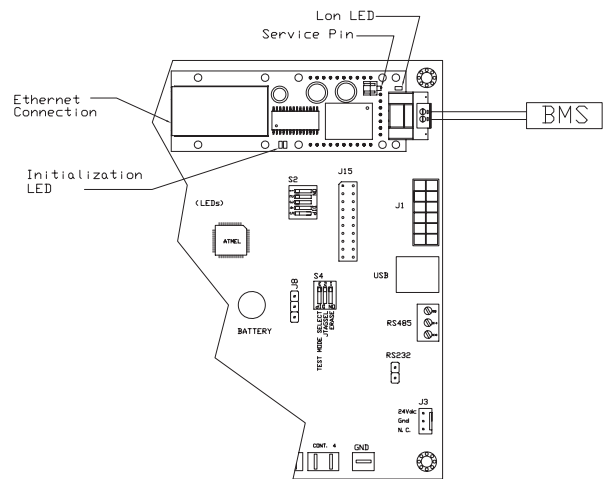

Figure 46-2. LON Wiring

BACnet™ Protocol Setup

1. Attach processor into upper right hand corner of main pc board.
 - a. BACnet™ MSTP - The ethernet connection should be going to the inside of the board.
 - b. BACnet™ IP - The ethernet connection goes to the outside of the board.Make sure that all pins are seated properly and making a good connection. (See Figure 47-1)

2. Connection

- a. BACnet™ MSTP - Connect three-wire BMS system to RS485 terminal on processor.
 - b. BACnet™ IP – Connect to ethernet port.
3. Make sure that all proper connections are made and that the installation instructions that start on page 6 have been adhered to. Power unit on.

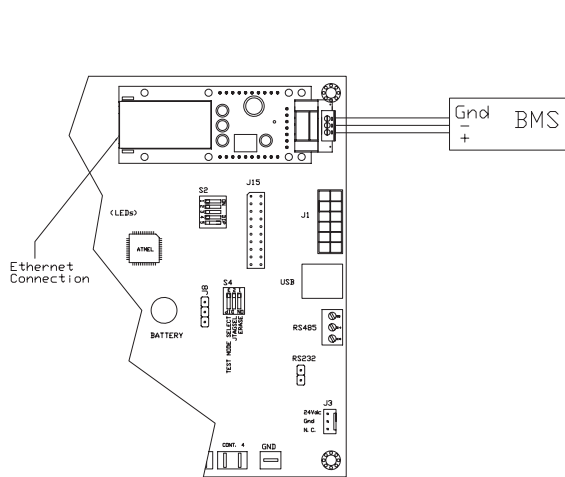

Figure 47-1. BACnet™ MSTP Wiring

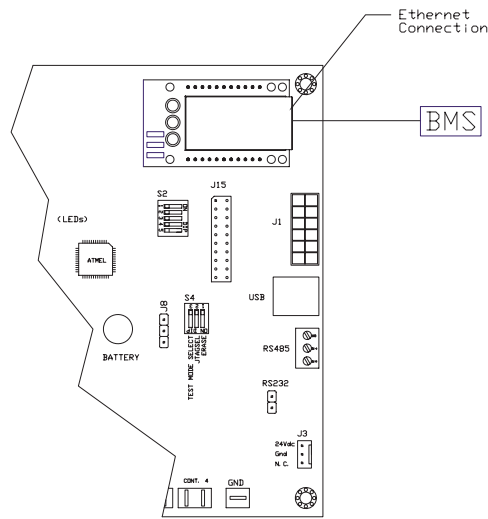

Figure 47-2. BACnet™ IP Wiring

4. With the humidifier powered off refer to the Dip Switch Settings for Processor table on pages 52-55 for the required dipswitch settings and make the required changes.
- 5) When the humidifier is powered access the Operation Setup menu through the front display and set the following information:
 - a. Network Mode – Modbus
 - b. Comm Address - 1
6. Now the changes to the actual unit are complete use Table 49-1 BACnet™ Variants List to help set up the required points in the Building Management System.
- 7) The device should be communicating.

Controlling the Humidifier through Communication Port

If you are planning on sending a percent output via communication port follow these instructions. If a controlling humidistat or the onboard controller on the humidifier with sensors are being used these instructions do not apply to your application.

1. On the BMS system verify that the Network is “enabled” and that the Sensor Select is “humidistat”.
2. Write the percent demand (0-100) to:
 - a. Modbus – data address 40002
 - b. BACnet™ – Analog Output
 - c. LonWorks™ - Data Array Name SINTA, Data Array Offset 2.

Obtaining xif File using RUInet

1. Run RUInet. Software can be found at www.protoconnector.com.
2. In the main menu of RUInet, type ‘U’ for upload.
3. Type ‘O’ for other.
4. Type ‘R’ for remote.
5. Type ‘fserver.xif’ and hit the ‘Enter’ key.
6. Type ‘U’ to upload the file
7. If you are running RUInet through the ruinet.exe, the xif file will be saved in the same directory as the RUInet executable.
8. If you are running RUINET through the Remote User Interface icon on the desktop, the xif file will be saved in:
Start -> All Programs -> FieldServer Utilities -> Config File Folder

Additional Questions

If you continue to have issues connecting via one of these types of protocols we would encourage you to test the setup using one of the list programs.

Modbus – Modbus Poll

BACnet™ – BACbeat by Polarsoft

LonWorks™ - Echelon LonMaker.

Instructions on how to download and use this software to connect with the Armstrong humidifier can be found on www.armstronginternational.com.

Table 49-1. BACnet™ Variant List

BACnet™ data type	Address	Description	Value / (Unit)	Attribute
Binary Input	1	Fill valve status	0:off 1:on	read only
	2	Drain valve status	0:off 1:on	
	3	contactor 1 status	0:off 1:on	
	4	contactor 2 status	0:off 1:on	
	5	contactor 3 status	0:off 1:on	
	6	contactor 4 status	0:off 1:on	
Binary Value	1	comm type	0:485 1:PSP	read / write
	2	Sensor select	0:Humidistat 1:RH sensor or On/Off	
	3	High limit sensor select	0:not use 1:use	
	4	Outside temperature	0:not use 1:use	
	5	Modulating Fill enable	0:enable 1:disable	
Analog Input	1	Desired RH / Demand	(%)	read only
	2	Steam Output	(kg/hr)	
	3	Water level	0:low 1:normal 2:high 3:exception	
	4	Run status	0:Idle 1:Steam gen. 2:Cycle drain 3:End of season drain 4:Bed dring 5:Failure 6:Drain 7:heat 8:Manual drain 9:Fill 10: Test 11: Manual stop 12: Empty drain	
	5	Bed life	(hours)	
	6	Bed life	(Minutes)	
	7	Run Time	(hours)	
	8	Run Time	(Minutes)	
	9	Drain Freq	(hours)	
	10	Drain Freq	(Minutes)	
	11	Idle Time	(hours)	
	12	Idle Time	(Minutes)	
	13	RH / Demand (Analog input)	(%)	
	14	Duct value	(%)	
	15	Outside temperature	(°C)	
	16	Water temperature	(°C)	
	17	Heat temperature	(°C)	
	18	Failure	1:Over temperature 2:High humidity/sail switch circuit is open 3:Illegal level switch state 4:Unit have reached 100% of bed life 5:Fill time out to low level 6:Water level dropped below level during normal run 7:Fill time out from low to high level 8:Water level above high level time out 9:Water level has not dropped below low level during an emptydrain 10:End of bed dring	
	19	Contactor number	1,2,3,4	
	20	Heating Element Power	0:1000W 1:3000 2:5000W 3:6650W 4:8000W	
Analog Value	1	Language Select	0:English 1:Chinese	read / write
	2	Set RH / Demand	(%)	
	3	Duct High Limit set point	(%)	
	4	Outside temp. high set point	(°C)	
	5	Outside temp. low set point	(°C)	
	6	Outside RH low set point	(%)	
	7	Run mode	0:Steam Gen 1:Manual Drain 2:Manual Fill 3:Unit stop	
	8	AQUASTAT	(°C)	
	9	Bed Life	0:Disabled 1:250hours 2:500hours 3:750hours 4:1000hours 5:1250hours 6:1500hours 7:1750hours 8:2000hours 9:2250hours 10:2500hours 11:2750hours 12:3000 hours	
	10	Drain Cycle	0:6hours 1:12hours 2:24hours 3:48hours 4:96hours 5:Real time drain	
	11	Drain duration	0:1Minutes 1:5Minutes 2:10Minutes	
	12	Signal type	0:0-10V 1:0-5V 2:1.9-3.9V 3:4-20mA	
	13	PID_DIV		
	14	PID_PB		
	15	PID_SI	(second)	
	16	PID_DG		
	17	Modulating Fill Cycle	(second)	
	18	Modulating Fill duration	(second)	
	19	Water temp. compensate	(°C)	
	20	Themocouple compensate	(°C)	
Analog Value (debug only)	21	First run		read / write
	22	Idle time	(hour) test for End of seanson drain	
	23	Drain time	(hour) test for Cycle drain	
	24	Bed life	(hour) test for End of Life	
	25	Bed drying time	(hour) test for whole Bed drying cycles, 96 hours max.	
	26	Bed drying time	(minute) test for one Bed Drying cycle, 30 minutes max.	
Analog Value	27	CAPACITY ADJUSTMENT	(%) ranges between 50 -100.	read / write
	28	NETWORK CONTROL	four levels NETWORK - MONITORING: All controls and changes to the unit must be done locally, but network monitoring is active. NETWORK - LOCAL STAT: local humidistat controls unit, but the user can make changes to all the other timers through the network. NETWORK - LOCAL SENSOR: local sensors control unit, but the user can make changes to all the other timers and setpoint through the network. NETWORK - FULL CONTROL: ALL controls are done thru the network, as well as changes to all the timers.	

Table 50-1. Modbus Variant List

Address	Description	Value / (unit)	Function Number	Data Class
10001	Fill valve status	0:off 1:on	function 2, read only	BI
10002	Drain valve status	0:off 1:on		
10003	contactor 1 status	0:off 1:on		
10004	contactor 2 status	0:off 1:on		
10005	contactor 3 status	0:off 1:on		
10006	contactor 4 status	0:off 1:on		
1	comm type	0:485 1:PSP	function 1, read only : function 5, 15 write	BV
2	Sensor select	0:Humidistat 1:RH sensor or On/Off		
3	High limit sensor select	0:not use 1:use		
4	Outside temperature	0:not use 1:use		
5	Modulating Fill enable	0:enable 1:disable		
30001	Desired RH / Demand	(%)	function 4, read only	AI
30002	Steam Output	(kg/hr)		
30003	Water level	0:low 1:normal 2:high 3:exception		
30004	Run status	0:Idle 1:Steam gen. 2:Cycle drain 3:End of season drain 4:Bed dring 5:Failure 6:Drain 7:heat 8:Manual drain 9:Fill 10: Test 11: Manual stop 12: Empty drain		
30005	Bed life	(hours)		
30006	Bed life	(Minutes)		
30007	Run Time	(hours)		
30008	Run Time	(Minutes)		
30009	Drain Freq	(hours)		
30010	Drain Freq	(Minutes)		
30011	Idle Time	(hours)		
30012	Idle Time	(Minutes)		
30013	RH / Demand (Analog input)	(%)		
30014	Duct value	(%)		
30015	Outside temperature	(°C)		
30016	Water temperature	(°C)		
30017	Heat temperature	(°C)		
30018	Failure	1:Over temperature 2:High humidity/sail switch circuit is open 3:Illegal level switch state 4:Unit have reached 100% of bed life 5:Fill time out to low level 6:Water level dropped below level during normal run 7:Fill time out from low to high level 8:Water level above high level time out 9:Water level has not dropped below low level during an emptydrain 10:End of bed dring		
30019	Contactor number	1,2,3,4		
30020	Heating Element Power	0:1000W 1:3000 2:5000W 3:6650W 4:8000W		

Table 51-1. Modbus Variant List, continued

Address	Description	Value / (unit)	Function Number	Data Class
40001	Language Select	0:English 1:Chinese	function 3 read only, function 6, 16 write	AV
40002	Set RH / Demand	(%)		
40003	Duct High Limit set point	(%)		
40004	Outside temp. high set point	(°C)		
40005	Outside temp. low set point	(v)		
40006	Outside RH low set point	(%)		
40007	Run mode	0:Steam Gen 1:Manual Drain 2:Manual Fill 3:Unit stop		
40008	AQUASTAT	(°C)		
40009	Bed Life	0:Disabled 1:250hours 2:500hours 3:750hours 4:1000hours 5:1250hours 6:1500hours 7:1750hours 8:2000hours 9:2250hours 10:2500hours 11:2750hours 12:3000 hours		
40010	Drain Cycle	0:6hours 1:12hours 2:24hours 3:48hours 4:96hours 5:Real time drain		
40011	Drain duration	0:1Minutes 1:5Minutes 2:10Minutes		
40012	Signal type	0:0-10V 1:0-5V 2:1.9-3.9V 3:4-20mA		
40013	PID_DIV			
40014	PID_PB			
40015	PID_SI	(second)		
40016	PID_DG			
40017	Modulating Fill Cycle	(second)		
40018	Modulating Fill duration	(second)		
40019	Water temp. compensate	(°C)		
40020	Thermocouple compensate	(°C)		
40021	First run		function 6, for debug only	AV
40022	Idle time	(hour) test for End of seanson drain		
40023	Drain time	(hour) test for Cycle drain		
40024	Bed life	(hour) test for End of Life		
40025	Bed drying time	(hour) test for whole Bed drying cycles, 96 hours max.		
40026	Bed drying time	(minute) test for one Bed Drying cycle, 30 minutes max.	function 3 read only, function 6, 16 write	AV
40027	CAPACITY ADJUSTMENT	(%) ranges between 50 -100.		
40028	NETWORK CONTROL	four levels NETWORK - MONITORING: All controls and changes to the unit must be done locally, but network monitoring is active. NETWORK - LOCAL STAT: local humidistat controls unit, but the user can make changes to all the other timers through the network. NETWORK - LOCAL SENSOR: local sensors control unit, but the user can make changes to all the other timers and setpoint through the network. NETWORK - FULL CONTROL: ALL controls are done thru the network, as well as changes to all the timers.		

Dip Switch Settings for Processor

Profile					B1	B2	B3	B4	
PSP to BACnet IP/BACnet MSTP HC6000					Off	Off	Off	Off	
PSP to Metasys N2 HC6000					On	Off	Off	Off	
Modbus RTU to BACnet IP/BACnet MSTP HC6000					Off	On	Off	Off	
Modbus RTU to Metasys N2 HC6000					On	On	Off	Off	
Modbus RTU to BACnet IP/BACnet MSTP HC6000 Legacy					Off	Off	On	Off	
Modbus RTU to Metasys N2 HC6000 Legacy					On	Off	On	Off	
A1	A2	A3	A4	A5	A6	A7	A8	Address	
Off	Off	Off	Off	Off	Off	Off	Off	0	
On	Off	Off	Off	Off	Off	Off	Off	1	
Off	On	Off	Off	Off	Off	Off	Off	2	
On	On	Off	Off	Off	Off	Off	Off	3	
Off	Off	On	Off	Off	Off	Off	Off	4	
On	Off	On	Off	Off	Off	Off	Off	5	
Off	On	On	Off	Off	Off	Off	Off	6	
On	On	On	Off	Off	Off	Off	Off	7	
Off	Off	Off	On	Off	Off	Off	Off	8	
On	Off	Off	On	Off	Off	Off	Off	9	
Off	On	Off	On	Off	Off	Off	Off	10	
On	On	Off	On	Off	Off	Off	Off	11	
Off	Off	On	On	Off	Off	Off	Off	12	
On	Off	On	On	Off	Off	Off	Off	13	
Off	On	On	On	Off	Off	Off	Off	14	
On	On	On	On	Off	Off	Off	Off	15	
Off	Off	Off	Off	On	Off	Off	Off	16	
On	Off	Off	Off	On	Off	Off	Off	17	
Off	On	Off	Off	On	Off	Off	Off	18	
On	On	Off	Off	On	Off	Off	Off	19	
Off	Off	On	Off	On	Off	Off	Off	20	
On	Off	On	Off	On	Off	Off	Off	21	
Off	On	On	Off	On	Off	Off	Off	22	
On	On	On	Off	On	Off	Off	Off	23	
Off	Off	Off	On	On	Off	Off	Off	24	
On	Off	Off	On	On	Off	Off	Off	25	
Off	On	Off	On	On	Off	Off	Off	26	
On	On	Off	On	On	Off	Off	Off	27	
Off	Off	On	On	On	Off	Off	Off	28	
On	Off	On	On	On	Off	Off	Off	29	
Off	On	On	On	On	Off	Off	Off	30	
On	On	On	On	On	Off	Off	Off	31	
Off	Off	Off	Off	Off	On	Off	Off	32	
On	Off	Off	Off	Off	On	Off	Off	33	
Off	On	Off	Off	Off	On	Off	Off	34	
On	On	Off	Off	Off	On	Off	Off	35	
Off	Off	On	Off	Off	On	Off	Off	36	
On	Off	On	Off	Off	On	Off	Off	37	
Off	On	On	Off	Off	On	Off	Off	38	
On	On	On	Off	Off	On	Off	Off	39	
Off	Off	Off	On	Off	On	Off	Off	40	
On	Off	Off	On	Off	On	Off	Off	41	
Off	On	Off	On	Off	On	Off	Off	42	
On	On	Off	On	Off	On	Off	Off	43	
Off	Off	On	On	Off	On	Off	Off	44	
On	Off	On	On	Off	On	Off	Off	45	
Off	On	On	On	Off	On	Off	Off	46	
On	On	On	On	Off	On	Off	Off	47	
Off	Off	Off	Off	On	On	Off	Off	48	
On	Off	Off	Off	On	On	Off	Off	49	
Off	On	Off	Off	On	On	Off	Off	50	
On	On	Off	Off	On	On	Off	Off	51	
Off	Off	On	Off	On	On	Off	Off	52	
On	Off	On	Off	On	On	Off	Off	53	
Off	On	On	Off	On	On	Off	Off	54	
On	On	On	Off	On	On	Off	Off	55	
Off	Off	Off	On	On	On	Off	Off	56	
On	Off	Off	On	On	On	Off	Off	57	
Off	On	Off	On	On	On	Off	Off	58	
On	On	Off	On	On	On	Off	Off	59	
Off	Off	On	On	On	On	Off	Off	60	
On	Off	On	On	On	On	Off	Off	61	
Off	On	On	On	On	On	Off	Off	62	
On	On	On	On	On	On	Off	Off	63	
Off	Off	Off	Off	Off	Off	On	Off	64	
On	Off	Off	Off	Off	Off	On	Off	65	

Dip Switch Settings - Continued

Profile					B1	B2	B3	B4
PSP to BACnet IP/BACnet MSTP HC6000					Off	Off	Off	Off
PSP to Metasys N2 HC6000					On	Off	Off	Off
Modbus RTU to BACnet IP/BACnet MSTP HC6000					Off	On	Off	Off
Modbus RTU to Metasys N2 HC6000					On	On	Off	Off
Modbus RTU to BACnet IP/BACnet MSTP HC6000 Legacy					Off	Off	On	Off
Modbus RTU to Metasys N2 HC6000 Legacy					On	Off	On	Off
A1	A2	A3	A4	A5	A6	A7	A8	Address
Off	On	Off	Off	Off	Off	On	Off	66
On	On	Off	Off	Off	Off	On	Off	67
Off	Off	On	Off	Off	Off	On	Off	68
On	Off	On	Off	Off	Off	On	Off	69
On	On	On	Off	Off	Off	On	Off	71
Off	Off	Off	On	Off	Off	On	Off	72
On	Off	Off	On	Off	Off	On	Off	73
Off	On	Off	On	Off	Off	On	Off	74
On	On	Off	On	Off	Off	On	Off	75
Off	Off	On	On	Off	Off	On	Off	76
On	Off	On	On	Off	Off	On	Off	77
Off	On	On	On	Off	Off	On	Off	78
On	On	On	On	Off	Off	On	Off	79
Off	Off	Off	Off	On	Off	On	Off	80
On	Off	Off	Off	On	Off	On	Off	81
Off	On	Off	Off	On	Off	On	Off	82
On	On	Off	Off	On	Off	On	Off	83
Off	Off	On	Off	On	Off	On	Off	84
On	Off	On	Off	On	Off	On	Off	85
Off	On	On	Off	On	Off	On	Off	86
On	On	On	Off	On	Off	On	Off	87
Off	Off	Off	On	On	Off	On	Off	88
On	Off	Off	On	On	Off	On	Off	89
Off	On	Off	On	On	Off	On	Off	90
On	On	Off	On	On	Off	On	Off	91
Off	Off	On	On	On	Off	On	Off	92
On	Off	On	On	On	Off	On	Off	93
Off	On	On	On	On	Off	On	Off	94
On	On	On	On	On	Off	On	Off	95
Off	Off	Off	Off	Off	On	On	Off	96
On	Off	Off	Off	Off	On	On	Off	97
Off	On	Off	Off	Off	On	On	Off	98
On	On	Off	Off	Off	On	On	Off	99
Off	Off	On	Off	Off	On	On	Off	100
On	Off	On	Off	Off	On	On	Off	101
Off	On	On	Off	Off	On	On	Off	102
On	On	On	Off	Off	On	On	Off	103
Off	Off	Off	On	Off	On	On	Off	104
On	Off	Off	On	Off	On	On	Off	105
Off	On	Off	On	Off	On	On	Off	106
On	On	Off	On	Off	On	On	Off	107
Off	Off	On	On	Off	On	On	Off	108
On	Off	On	On	Off	On	On	Off	109
Off	On	On	On	Off	On	On	Off	110
On	On	On	On	Off	On	On	Off	111
Off	Off	Off	Off	On	On	On	Off	112
On	Off	Off	Off	On	On	On	Off	113
Off	On	Off	Off	On	On	On	Off	114
On	On	Off	Off	On	On	On	Off	115
Off	Off	On	Off	On	On	On	Off	116
On	Off	On	Off	On	On	On	Off	117
Off	On	On	Off	On	On	On	Off	118
On	On	On	Off	On	On	On	Off	119
Off	Off	Off	On	On	On	On	Off	120
On	Off	Off	On	On	On	On	Off	121
Off	On	Off	On	On	On	On	Off	122
On	On	Off	On	On	On	On	Off	123
Off	Off	On	On	On	On	On	Off	124
On	Off	On	On	On	On	On	Off	125
Off	On	On	On	On	On	On	Off	126
On	On	On	On	On	On	On	Off	127
Off	Off	Off	Off	Off	Off	Off	On	128
On	Off	Off	Off	Off	Off	Off	On	129
Off	On	Off	Off	Off	Off	Off	On	130

Dip Switch Settings - Continued

Profile					B1	B2	B3	B4
PSP to BACnet IP/BACnet MSTP HC6000					Off	Off	Off	Off
PSP to Metasys N2 HC6000					On	Off	Off	Off
Modbus RTU to BACnet IP/BACnet MSTP HC6000					Off	On	Off	Off
Modbus RTU to Metasys N2 HC6000					On	On	Off	Off
Modbus RTU to BACnet IP/BACnet MSTP HC6000 Legacy					Off	Off	On	Off
Modbus RTU to Metasys N2 HC6000 Legacy					On	Off	On	Off
A1	A2	A3	A4	A5	A6	A7	A8	Address
On	On	Off	Off	Off	Off	Off	On	131
Off	Off	On	Off	Off	Off	Off	On	132
On	Off	On	Off	Off	Off	Off	On	133
Off	On	On	Off	Off	Off	Off	On	134
On	On	On	Off	Off	Off	Off	On	135
Off	Off	Off	On	Off	Off	Off	On	136
On	Off	Off	On	Off	Off	Off	On	137
Off	On	Off	On	Off	Off	Off	On	138
On	On	Off	On	Off	Off	Off	On	139
Off	Off	On	On	Off	Off	Off	On	140
On	Off	On	On	Off	Off	Off	On	141
Off	On	On	On	Off	Off	Off	On	142
On	On	On	On	Off	Off	Off	On	143
Off	Off	Off	Off	On	Off	Off	On	144
On	Off	Off	Off	On	Off	Off	On	145
Off	On	Off	Off	On	Off	Off	On	146
On	On	Off	Off	On	Off	Off	On	147
Off	Off	On	Off	On	Off	Off	On	148
On	Off	On	Off	On	Off	Off	On	149
Off	On	On	Off	On	Off	Off	On	150
On	On	On	Off	On	Off	Off	On	151
Off	Off	Off	On	On	Off	Off	On	152
On	Off	Off	On	On	Off	Off	On	153
Off	On	Off	On	On	Off	Off	On	154
On	On	Off	On	On	Off	Off	On	155
Off	Off	On	On	On	Off	Off	On	156
On	Off	On	On	On	Off	Off	On	157
Off	On	On	On	On	Off	Off	On	158
On	On	On	On	On	Off	Off	On	159
Off	Off	Off	Off	Off	On	Off	On	160
On	Off	Off	Off	Off	On	Off	On	161
Off	On	Off	Off	Off	On	Off	On	162
On	On	Off	Off	Off	On	Off	On	163
Off	Off	On	Off	Off	On	Off	On	164
On	Off	On	Off	Off	On	Off	On	165
Off	On	On	Off	Off	On	Off	On	166
On	On	On	Off	Off	On	Off	On	167
Off	Off	Off	On	Off	On	Off	On	168
On	Off	Off	On	Off	On	Off	On	169
Off	On	Off	On	Off	On	Off	On	170
On	On	Off	On	Off	On	Off	On	171
Off	Off	On	On	Off	On	Off	On	172
On	Off	On	On	Off	On	Off	On	173
Off	On	On	On	Off	On	Off	On	174
On	On	On	On	Off	On	Off	On	175
Off	Off	Off	Off	On	On	Off	On	176
On	Off	Off	Off	On	On	Off	On	177
Off	On	Off	Off	On	On	Off	On	178
On	On	Off	Off	On	On	Off	On	179
Off	Off	On	Off	On	On	Off	On	180
On	Off	On	Off	On	On	Off	On	181
Off	On	On	Off	On	On	Off	On	182
On	On	On	Off	On	On	Off	On	183
Off	Off	Off	On	On	On	Off	On	184
On	Off	Off	On	On	On	Off	On	185
Off	On	Off	On	On	On	Off	On	186
On	On	Off	On	On	On	Off	On	187
Off	Off	On	On	On	On	Off	On	188
On	Off	On	On	On	On	Off	On	189
Off	On	On	On	On	On	Off	On	190
On	On	On	On	On	On	Off	On	191
Off	Off	Off	Off	Off	Off	On	On	192
On	Off	Off	Off	Off	Off	On	On	193
Off	On	Off	Off	Off	Off	On	On	194
On	On	Off	Off	Off	Off	On	On	195

Dip Switch Settings - Continued

Profile					B1	B2	B3	B4
PSP to BACnet IP/BACnet MSTP HC6000					Off	Off	Off	Off
PSP to Metasys N2 HC6000					On	Off	Off	Off
Modbus RTU to BACnet IP/BACnet MSTP HC6000					Off	On	Off	Off
Modbus RTU to Metasys N2 HC6000					On	On	Off	Off
Modbus RTU to BACnet IP/BACnet MSTP HC6000 Legacy					Off	Off	On	Off
Modbus RTU to Metasys N2 HC6000 Legacy					On	Off	On	Off
A1	A2	A3	A4	A5	A6	A7	A8	Address
Off	Off	On	Off	Off	Off	On	On	196
On	Off	On	Off	Off	Off	On	On	197
Off	On	On	Off	Off	Off	On	On	198
On	On	On	Off	Off	Off	On	On	199
Off	Off	Off	On	Off	Off	On	On	200
On	Off	Off	On	Off	Off	On	On	201
Off	On	Off	On	Off	Off	On	On	202
On	On	Off	On	Off	Off	On	On	203
Off	Off	On	On	Off	Off	On	On	204
On	Off	On	On	Off	Off	On	On	205
Off	On	On	On	Off	Off	On	On	206
On	On	On	On	Off	Off	On	On	207
Off	Off	Off	Off	On	Off	On	On	208
On	Off	Off	Off	On	Off	On	On	209
Off	On	Off	Off	On	Off	On	On	210
On	On	Off	Off	On	Off	On	On	211
Off	Off	On	Off	On	Off	On	On	212
On	Off	On	Off	On	Off	On	On	213
Off	On	On	Off	On	Off	On	On	214
On	On	On	Off	On	Off	On	On	215
Off	Off	Off	On	On	Off	On	On	216
On	Off	Off	On	On	Off	On	On	217
Off	On	Off	On	On	Off	On	On	218
On	On	Off	On	On	Off	On	On	219
Off	Off	On	On	On	Off	On	On	220
On	Off	On	On	On	Off	On	On	221
Off	On	On	On	On	Off	On	On	222
On	On	On	On	On	Off	On	On	223
Off	Off	Off	Off	Off	On	On	On	224
On	Off	Off	Off	Off	On	On	On	225
Off	On	Off	Off	Off	On	On	On	226
On	On	Off	Off	Off	On	On	On	227
Off	Off	On	Off	Off	On	On	On	228
On	Off	On	Off	Off	On	On	On	229
Off	On	On	Off	Off	On	On	On	230
On	On	On	Off	Off	On	On	On	231
Off	Off	Off	On	Off	On	On	On	232
On	Off	Off	On	Off	On	On	On	233
Off	On	Off	On	Off	On	On	On	234
On	On	Off	On	Off	On	On	On	235
Off	Off	On	On	Off	On	On	On	236
On	Off	On	On	Off	On	On	On	237
Off	On	On	On	Off	On	On	On	238
On	On	On	On	Off	On	On	On	239
Off	Off	Off	Off	On	On	On	On	240
On	Off	Off	Off	On	On	On	On	241
Off	On	Off	Off	On	On	On	On	242
On	On	Off	Off	On	On	On	On	243
Off	Off	On	Off	On	On	On	On	244
On	Off	On	Off	On	On	On	On	245
Off	On	On	Off	On	On	On	On	246
On	On	On	Off	On	On	On	On	247
Off	Off	Off	On	On	On	On	On	248
On	Off	Off	On	On	On	On	On	249
Off	On	Off	On	On	On	On	On	250
On	On	Off	On	On	On	On	On	251
Off	Off	On	On	On	On	On	On	252
On	Off	On	On	On	On	On	On	253
Off	On	On	On	On	On	On	On	254
On	On	On	On	On	On	On	On	255

Dimensional Data

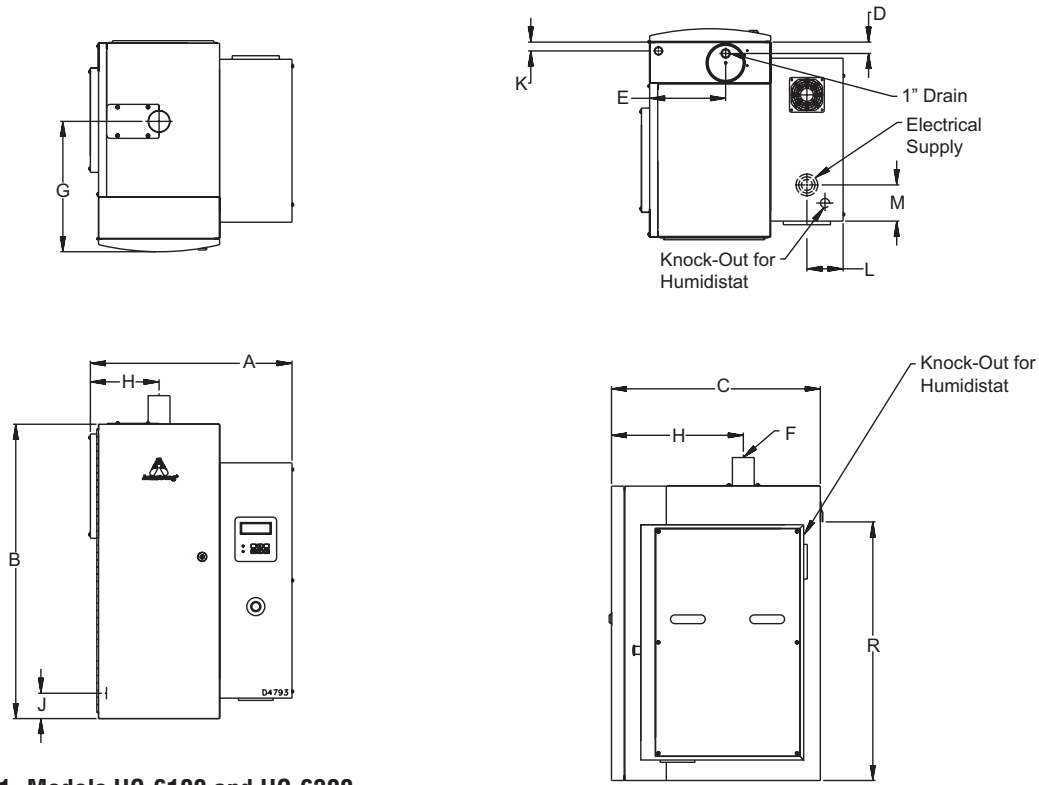

Figure 56-1. Models HC-6100 and HC-6300

	HC-6100 and HC-6300		HC-6500, HC-6700 and HC-6700DI	
	Inches	mm	Inches	mm
"A"-Width	21-15/16	557	26	660
"B"-Height	32-1/16	814	56-3/18	1428
"C"-Depth	22-1/3	576	32-3/32	815
"D"-Drain - Back	20	508	29-3/16	748
"E"-Drain - Side	9-1/8	232	11-1/2	293
"F"-Steam Discharge Tube	2-3/8	60	2-3/8	60
"G"-Steam Outlet - Side	7-1/2	190	9-1/2	241
"H"-Steam Outlet - Front	14-1/3	364	12-7/8	328
"J"-Supply Water - Bottom	1-27/32	47	1-7/8	47
"K"-Water Supply - Front	2-13/32	61	2-3/8	60
"L"-Electrical Supply - Side	18	457	22-1/16	560
"M"-Electrical Supply - Back	10-3/16	254	16-1/4	413
"Q"-Steam Dispersion Outlets	—	—	12-3/16	310
Water Supply Connection	3/8 compression fitting	10	1/2 compression fitting	12
Dry Weight (lbs (kg))	155 (70)		290 (130)	
Wet Weight (lbs (kg))	230 (105)		507 (230)	
Shipping Weight (lbs (kg))	175 (80)		330 (150)	

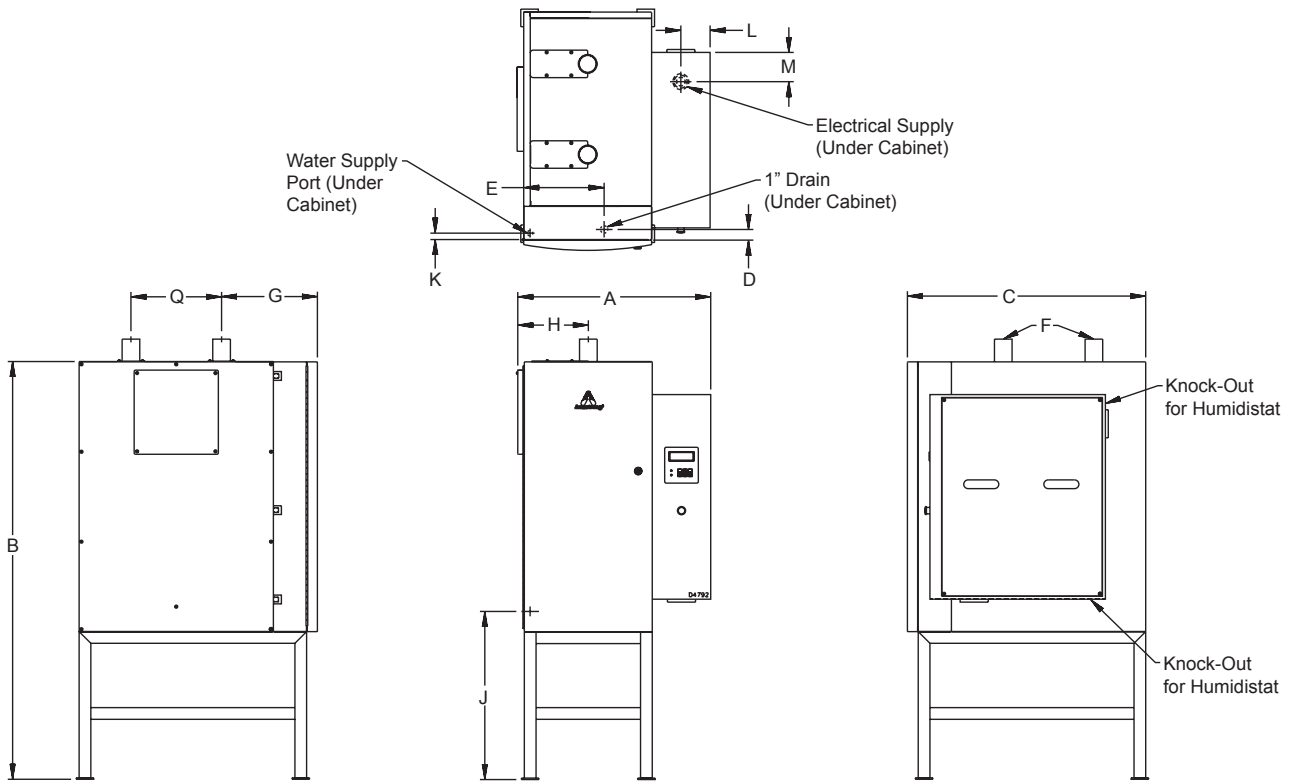

Figure 57-1. Models HC-6500 and HC-6700 — Front, Side, Top Views

Start-Up Checklist

Armstrong HC6000 Series Pre Start-Up Checklist

Humidifier model: _____ Serial #: _____

Voltage: _____ ph: _____ KW : _____

Steam Capacity: _____ lbs/hr.

Job name: _____

Unit Tag: _____

Inspected by: _____ Date: ____/____/____

Water Type:

Tap water Softened water

DI water RO water

Ionic Beds:

If tap water or softened water, were beds installed:

Yes Number of beds : _____ Date installed ____/____/____

No Remarks: _____

Humidifier Mounting:

24" Clearance needed:

Left side Obstruction: _____

Right side Obstruction: _____

Front Obstruction: _____

Steam Dispersion Piping:

Copper Stainless Steel Hose

Size: _____ Insulated

Length: _____

Number of elbows:

45° Elbows: _____

90° Elbows: _____

Slope up 1" per 12" Sloped back to drain

Slope down 1" per 12"

P-trap at bottom of every vertical down run Size: _____"

P-trap every 20 equivalent feet of dispersion piping Size: _____"

Steam Dispersion Type:

- Humidipack™ Expresspack Fan package (EHF)
- Dispersion Tube Dispersion Tube with Drain
- Other _____

Plumbing:

Inlet Water:

- Inlet water pressure between 25-120 psig

Drain Lines:

Size: _____

- Air gap located within 3' of humidifier
- Line pitched 1" per 12" away from humidifier
- Temp-R-Drain (condensate cooler)
- Other condensate cooler _____

Wiring:

- All wires connected securely
- No loose wires around PC board
- Proper breaker and wire size per Table 7-1 and 7-2 of HC6000 IOM

Control Wiring:

Installed

- High Limit Humidistat
- Mounted 10 feet downstream of dispersion
- Air proving / pressure switch
- Mounted upstream of dispersion
- Modulating Humidistat / Controller

Signal Type:

- 0-10 VDC 4-20 mA
- Communications
- Modbus BACnet LonWorks

Start-Up Procedure

Armstrong HC6000 Series Start Up Checklist

Humidifier model: _____ Serial # : _____

Voltage: _____ ph: _____ KW : _____

Steam Capacity: _____ lbs/hr. Unit Tag: _____

Job name: _____

Unit Tag: _____

Completed Start up Checklist

If checklist was not completed, complete before proceeding with start up.

Check and recheck proper incoming high voltage and high voltage terminals.

ex. Contactors, power module, fuse block and grounding lug.

Turn on water supply and check for leaks

Secure all access doors and panels.

Turn on main power to unit

Rotate the emergency stop button clockwise to turn the unit on

Refer to Principle of Operation in the HC6000 IOM for normal operation.

Start Up by : _____ Company: _____

Signed : _____ Date : ____/____/____

Limited Warranty and Remedy

Armstrong International, Inc. (“Armstrong”) warrants to the original user of those products supplied by it and used in the service and in the manner for which they are intended, that such products shall be free from defects in material and workmanship for a period of one (1) year from the date of installation, but not longer than 15 months from the date of shipment from the factory, [unless a Special Warranty Period applies, as listed below]. This warranty does not extend to any product that has been subject to misuse, neglect or alteration after shipment from the Armstrong factory. Except as may be expressly provided in a written agreement between Armstrong and the user, which is signed by both parties, Armstrong **DOES NOT MAKE ANY OTHER REPRESENTATIONS OR WARRANTIES, EXPRESS OR IMPLIED, INCLUDING, BUT NOT LIMITED TO, ANY IMPLIED WARRANTY OF MERCHANTABILITY OR ANY IMPLIED WARRANTY OF FITNESS FOR A PARTICULAR PURPOSE.**

The sole and exclusive remedy with respect to the above limited warranty or with respect to any other claim relating to the products or to defects or any condition or use of the products supplied by Armstrong, however caused, and whether such claim is based upon warranty, contract, negligence, strict liability, or any other basis or theory, is limited to Armstrong’s repair or replacement of the part or product, excluding any labor or any other cost to remove or install said part or product, or at Armstrong’s option, to repayment of the purchase price. As a condition of enforcing any rights or remedies relating to Armstrong products, notice of any warranty or other claim relating to the products must be given in writing to Armstrong: (i) within 30 days of last day of the applicable warranty period, or (ii) within 30 days of the date of the manifestation of the condition or occurrence giving rise to the claim, whichever is earlier. **IN NO EVENT SHALL ARMSTRONG BE LIABLE FOR SPECIAL, DIRECT, INDIRECT, INCIDENTAL OR CONSEQUENTIAL DAMAGES, INCLUDING, BUT NOT LIMITED TO, LOSS OF USE OR PROFITS OR INTERRUPTION OF BUSINESS.** The Limited Warranty and Remedy terms herein apply notwithstanding any contrary terms in any purchase order or form submitted or issued by any user, purchaser, or third party and all such contrary terms shall be deemed rejected by Armstrong.

Special Warranty Periods are as follows:

Series EHU-700 Electric Steam Humidifier, Series HC-6000 HumidiClean™ Humidifier and GFH Gas Fired Humidifier with Ionic Beds:

Two (2) years after installation, but not longer than 27 months after shipment from Armstrong’s factory.

HumidiClean™ Humidifiers

Series HC- 6100/6300/6500/6700

Installation, Operation and Maintenance Instructions

*Designs, materials, weights and performance ratings are approximate and subject to change without notice.
Visit armstronginternational.com for up-to-date information.*



Armstrong International
North America • Latin America • India • Europe / Middle East / Africa • China • Pacific Rim
armstronginternational.com