



MERIDIAN MODEL 3792

CORTERRA
ADA-COMPLIANT
KURVE DUAL BASIN

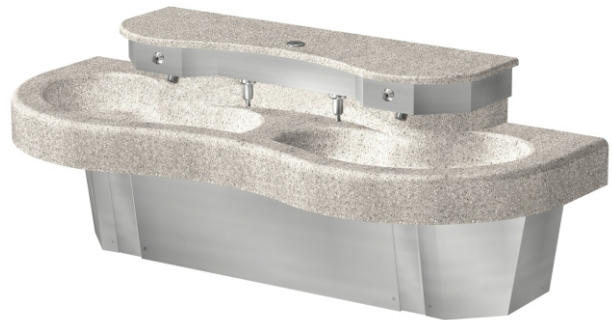

TABLE OF CONTENTS

Prior to Installation	2
Accessibility Overview	3
Dimensional Data	4
Rough-Ins	5 - 7
Installation	8 - 17
Piezo Adjustment.	18 - 20
Troubleshooting.	21 - 22
Cleaning and Maintenance.	23
Components & Repair Parts	24 - 29
Warranty Information	30

REQUIRED ITEMS FOR INSTALLATION - NOT SUPPLIED

- ✂ Chalk Line
- ✂ Hammer
- ✂ Carpenters Level
- ✂ 1/2" NPS Supply Angle Stops And 1/2" NPS Supply Flex Hose(s)
- ✂ 7/16" Hex Wrench
- ✂ 1/4" Slotted Tip Screwdriver For Metering Adjustment
- ✂ Plumbers Putty
- ✂ Teflon Tape
- ✂ Fixture Wall Anchors and Anchoring Hardware (and Appropriate Tools) - For 3/8" Punching (13 Count)
- ✂ Driver For 1/4" Shank Bit - For Center Reject Bit

ACORN ENGINEERING COMPANY
P.O. BOX 3527 • CITY OF INDUSTRY, CA 91744 U.S.A.
TOLL FREE 800-488-8999 :: LOCAL 626-336-4561
FAX 626-961-2200 :: www.acorneng.com



IMPORTANT

Important: Some options may slightly alter installation. To ensure proper installation review the manual thoroughly and verify rough-ins before beginning any work. File this manual with the owner or maintenance personnel upon completion of installation.

Industry standard wall backing, for wall hung fixtures, is required. Installer provided wall anchors and wall anchoring hardware must be appropriate for wall construction, and have a minimum pull-out rating of 1000 lbs. (453.6 kg).

ANSI, UFAS or ADA compliance is subject to the interpretation and requirements of the local code authority and is the responsibility of the installer for verification.

Single Temp Valve Assembly: Recommended working water pressure is 30 psi (2.07 bars) minimum to 100 psi (6.89 bars) maximum. Maximum temperature is 130°F (54.4°C). Maximum outlet temperature is recommended is 105°F (40.6°C). Valve assembly must be drained prior to being subjected to freezing temperatures. A checkstop is provided with this valve assembly.

T/P Mixing Valve Assembly: Recommended working water pressure is 30 psi (2.07 bars) minimum to 125 psi (8.62 bars) maximum. Maximum hot water temperature is 180°F (82°C). Temperature adjustment range is 85-115°F (29-46°C). Valve assembly must be drained prior to being subjected to freezing temperatures. The valve assembly has checks integral to the inlets however, angle stops are to be provided by the installer.

Prior to installation, supply lines must be flushed of all foreign material such as pipe dope, chips, or solder. Debris or foreign material in water supply may damage valve.

Teflon tape is recommended on all threaded waste and supply connections to reduce the possibility of leaks.

Provide 110-120VAC/60Hz/3A (MAX) electrical receptacle for factory supplied 120VAC/9VDC, 100mA plug-in transformer.

NOTE: Receptacle(s) must be wired to a GFCI protected circuit. Fixture must be earth grounded per N.E.C. (National Electrical Code).



ACCESSIBILITY OVERVIEW

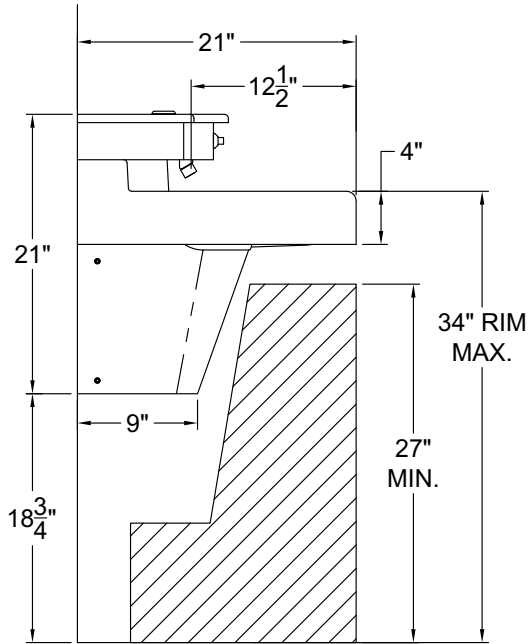

**ADA
Adult**

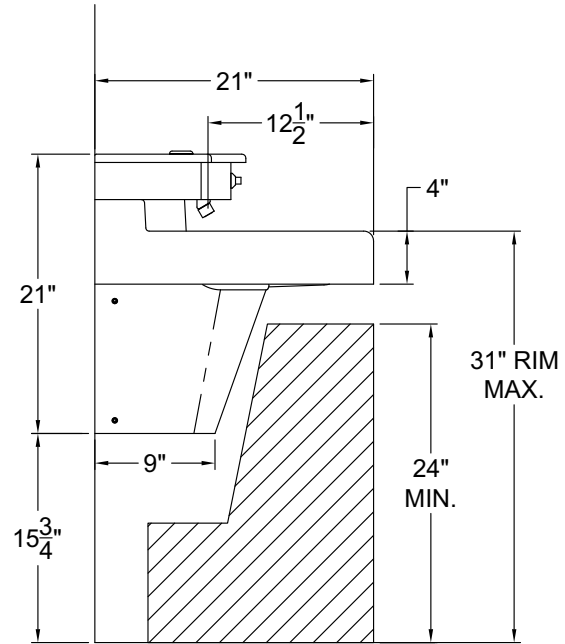

**ADA ages
6 thru 12**

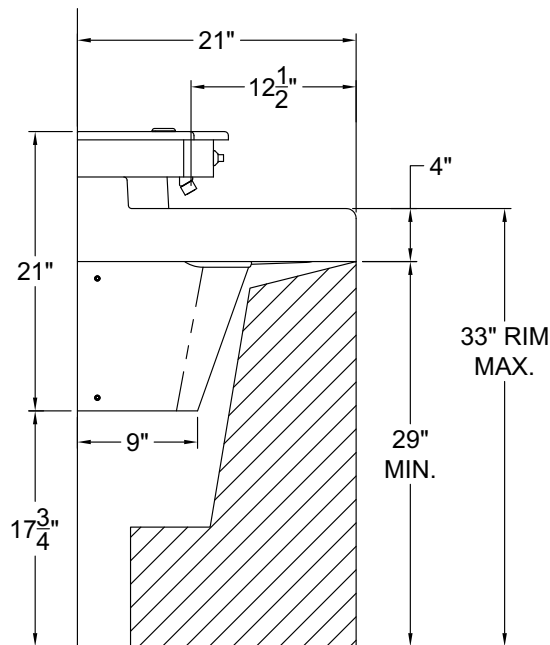

OBC



INSTALLATION, OPERATIONS & MAINTENANCE MANUAL

Please visit www.acorneng.com
for most current specifications.

MERIDIAN 3792

DIMENSIONAL DATA

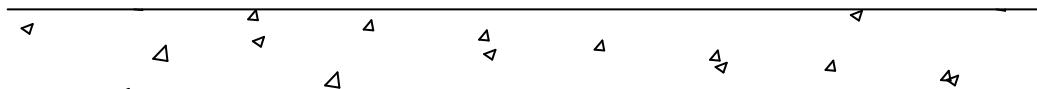
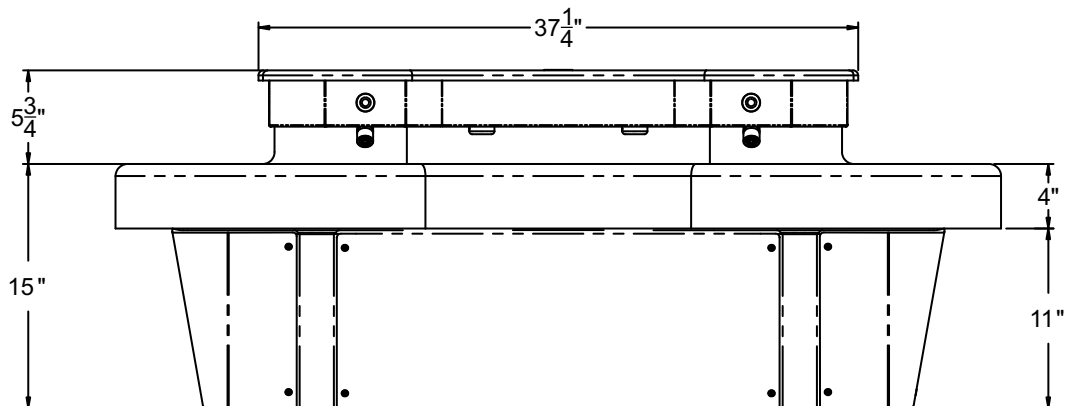
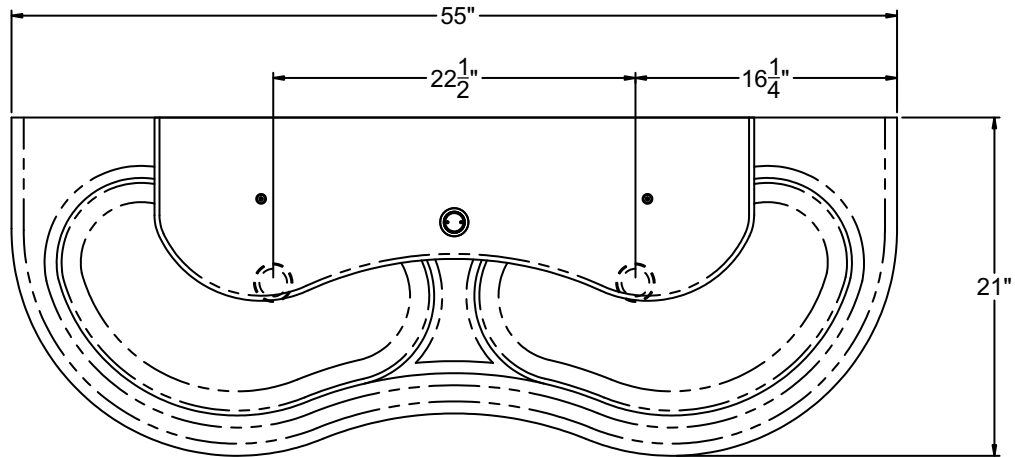
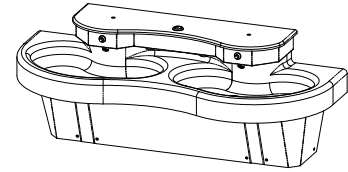



Please visit www.acorneng.com
for most current specifications.

ROUGH-IN DIMENSIONS -ADA (Adult)

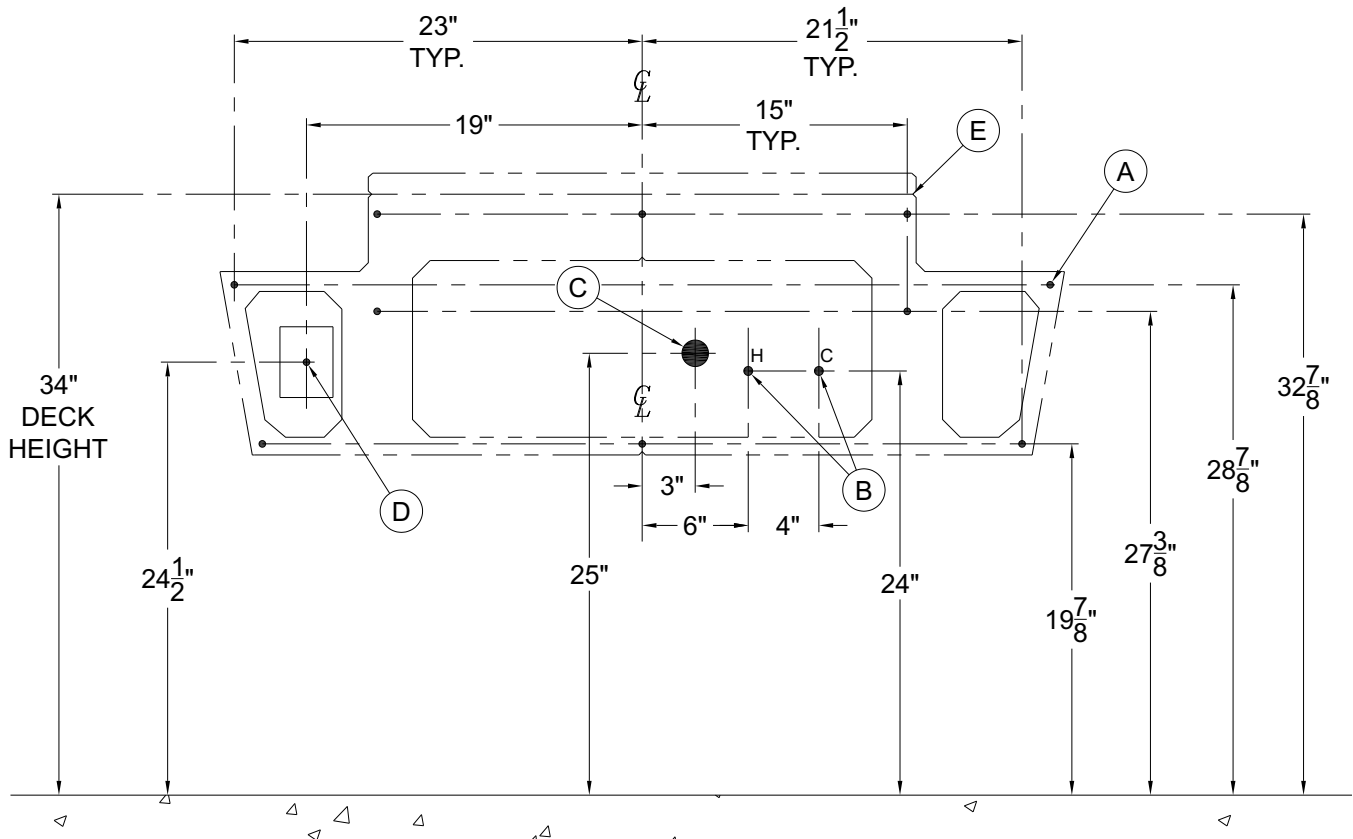

- Ⓐ - 3/8" Diameter Mounting Holes, For Anchoring Points, 10 Places.
- Ⓑ -Supply Stub-Outs with Stops for Valve 1/2" NPT Hot & Cold Supply Inlets.
- Ⓒ -Waste Outlet for 1-1/2" O.D. P-Trap.
- Ⓓ -120VAC, 60 Hz, 3A (Max.) GFCI Protected, Electrical Receptacle.
- Ⓔ -Frame "V" Notch.



Please visit www.acorneng.com
for most current specifications.

ROUGH-IN DIMENSIONS -ADA AGES 6 THRU 12 YEARS

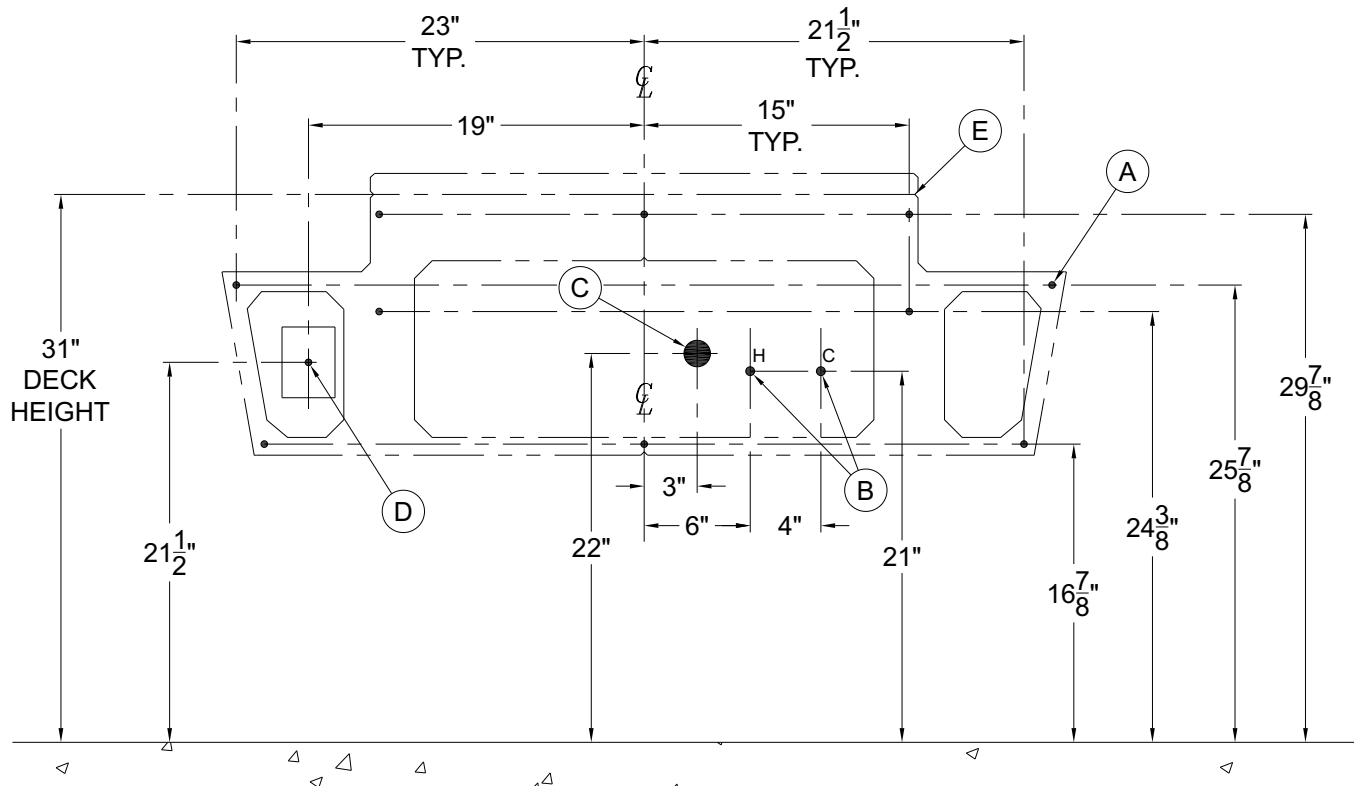

- Ⓐ - 3/8" Diameter Mounting Holes, For Anchoring Points, 10 Places.
- Ⓑ -Supply Stub-Outs with Stops for Valve 1/2" NPT Hot & Cold Supply Inlets.
- Ⓒ -Waste Outlet for 1-1/2" O.D. P-Trap.
- Ⓓ -120VAC, 60 Hz, 3A (Max.) GFCI Protected, Electrical Receptacle.
- Ⓔ -Frame "V" Notch.



ROUGH-IN DIMENSIONS -OBC ONTARIO BUILDING CODE

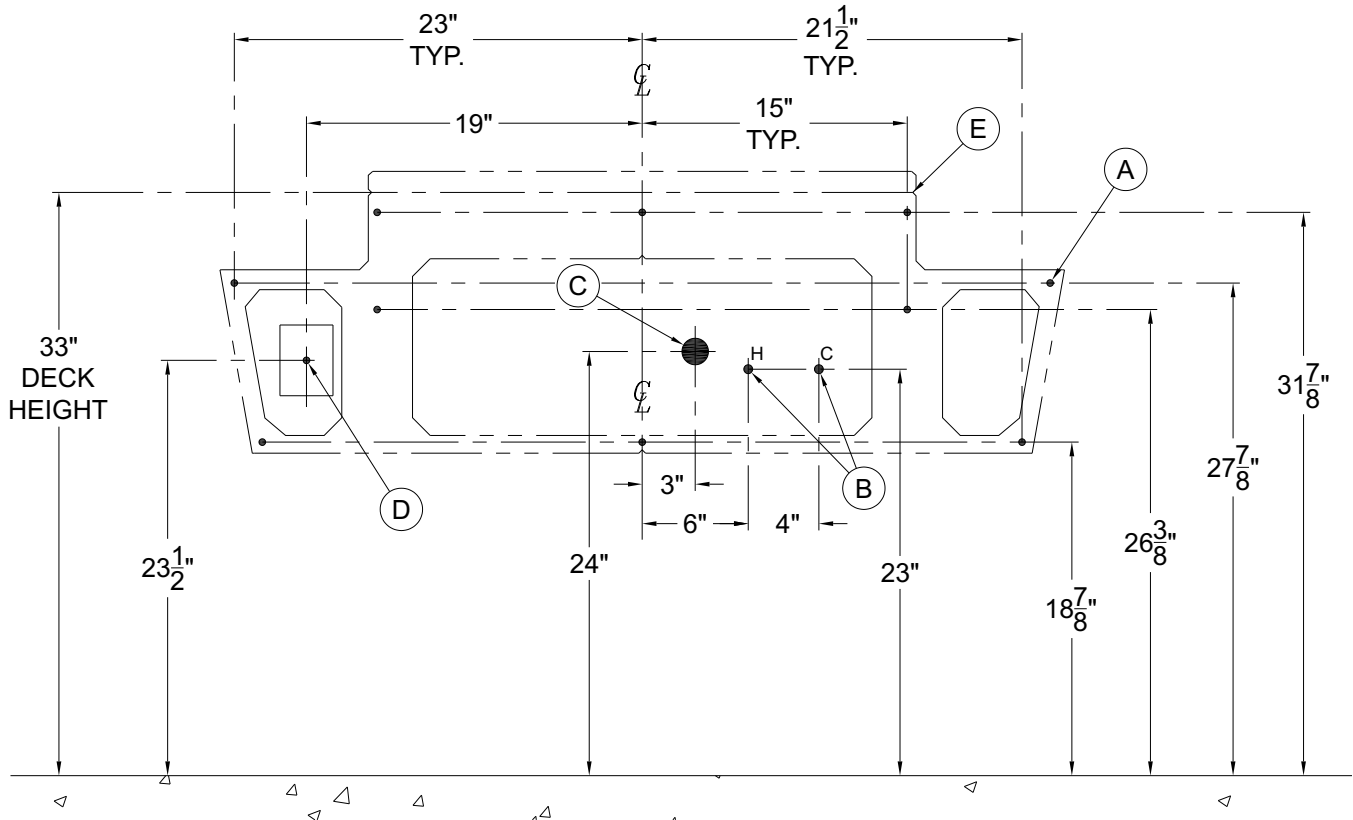

- Ⓐ - 3/8" Diameter Mounting Holes, For Anchoring Points, 10 Places.
- Ⓑ -Supply Stub-Outs with Stops for Valve 1/2" NPT Hot & Cold Supply Inlets.
- Ⓒ -Waste Outlet for 1-1/2" O.D. P-Trap.
- Ⓓ -120VAC, 60 Hz, 3A (Max.) GFCI Protected, Electrical Receptacle.
- Ⓔ -Frame "V" Notch.



Please visit www.acorneng.com
for most current specifications.

FIXTURE ANCHORING

- 1** Disassemble access panels and deck assembly from frame. Anchor frame to wall using 3/8" mounting hardware by others.

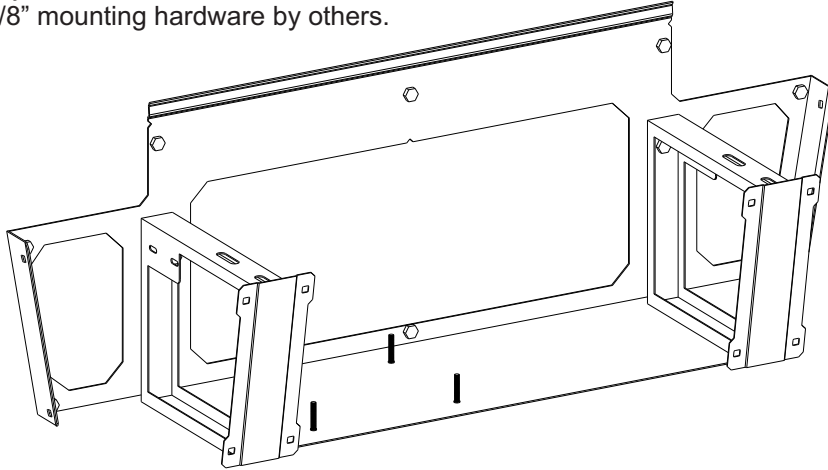

- 2** -See **DETAIL A**. Place deck assembly on frame, making sure angle engages behind frame joggle.
-See **DETAIL B**. Assemble underside of bowls to frame with 1/4"-20 x 1/2" hex bolts, 1/4" lock washers, and 1/4" fender washers provided.
-See **DETAIL C**. Assemble deck support flanges to outside of frame using 1/4"-20 x 1" hex bolts, 1/4" lock washers and 1/4" flat washers provided.

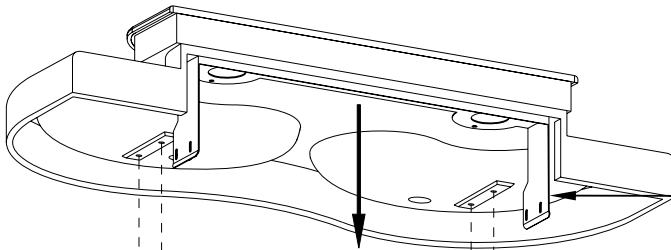

DETAIL B

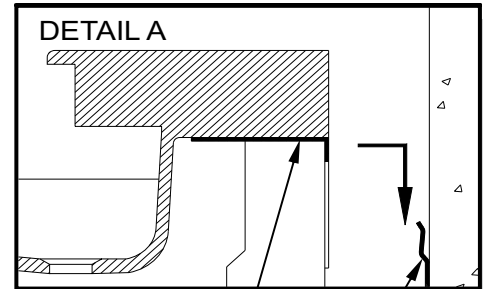
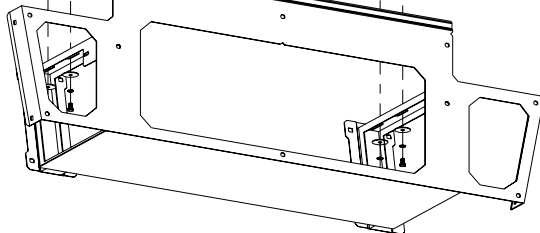

Angle
Frame Joggle

Deck Support Flanges

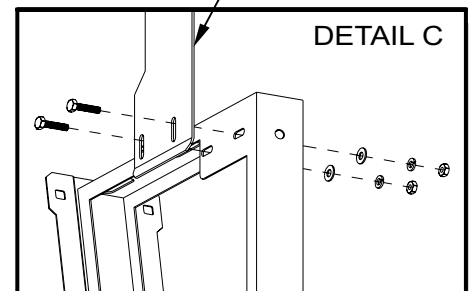

DETAIL C



INSTALLATION, OPERATIONS & MAINTENANCE MANUAL

Please visit www.acorneng.com for most current specifications.

MERIDIAN 3792



HINT: Teflon tape is recommended on all threaded waste and supply connections.

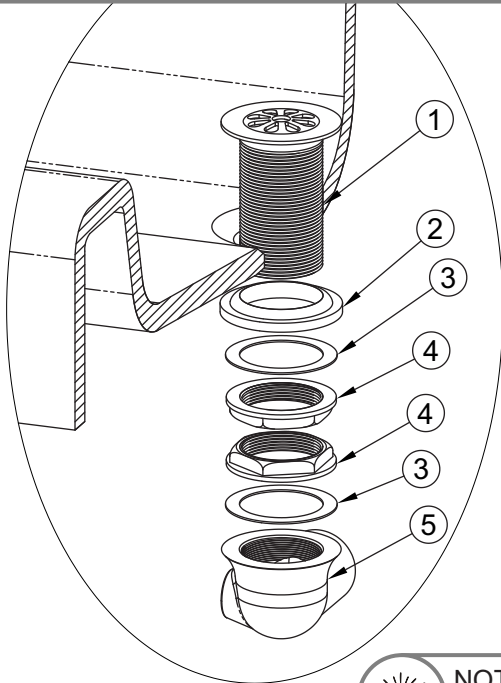

3 Install grid strainer and close elbow to bowl using plumber's putty.

- ① Grid Strainer w/ 1-1/2" -16 UNE Threads
- ② Rubber Gasket
- ③ Flat Fiber Washer
- ④ 1-1/2" -16 UNI Rough Chrome Brass Jam Nut
- ⑤ 1-1/2"-16 x 1-1/4" UNI Close Ell with 3/8" NPT Clean-Out Plug



NOTE: Continuous waste assembly will require field cutting and fitting by the installer.

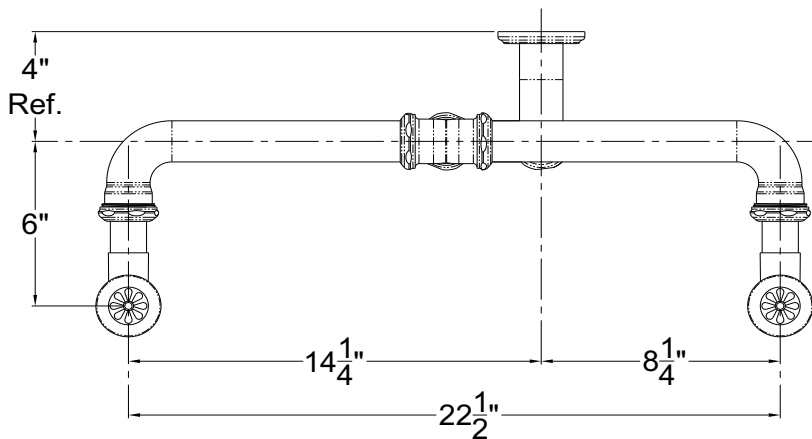

4 Assemble continuous waste piping using teflon tape on all threaded connections and make up waste connections to 1-1/2" P-Trap.



VALVE INSTALLATION

! IMPORTANT

Before making up the supply connections, the supply lines must be flushed of all foreign material such as pipe dope, pipe chips, solder, sand, etc.

MX-TP VALVE (-H HAND OPERATED SHOWN)

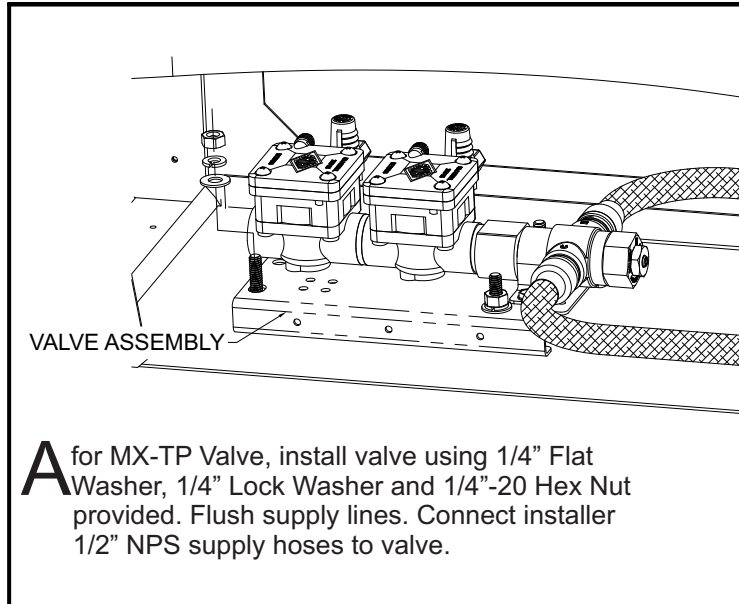

-ST SINGLE TEMPERATURE VALVE

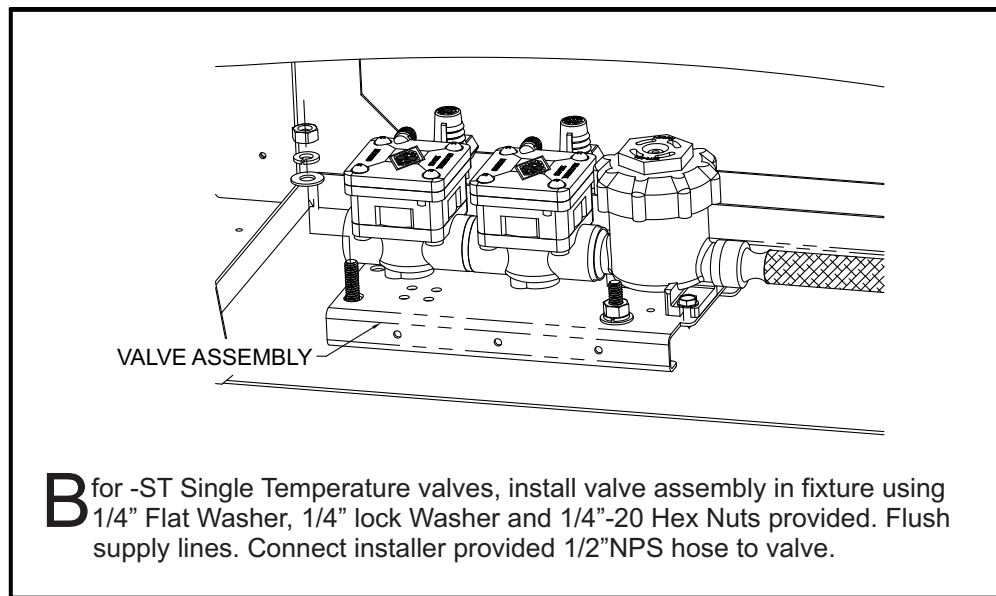



VALVE INSTALLATION & ADJUSTMENT

Valve Assembly Installation:

NOTE: Installation should be in accordance with accepted plumbing practices.

- 1) Locate suitable place for mounting the valve assembly. Valve assembly should be accessible for service and adjustment and as close to the point-of-use as possible. Wall anchors and anchoring hardware, for Ø3/8" mounting holes, provided by installer.
- 2) Connect hot and cold water to supply valve using 1/2" NPTE connections.
- 3) Connect outlet of tempering valve to spout(s) using 1/4" O.D. tube connections provided.
- 4) Turn on hot and cold water supplies. If any leaks are observed, hand tighten connections as necessary to stop leaks before proceeding.
- 5) Turn on fixture and allow water to flow for 2 minutes. Measure water temperature at outlet. If water is not at desired temperature, adjust as necessary.



Flush supply lines of all foreign material such as pipe dope, pipe chips, solder, sand etc. before making up supply connections.

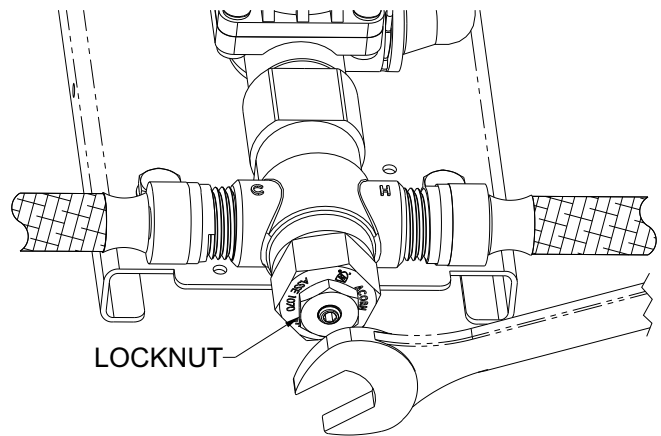
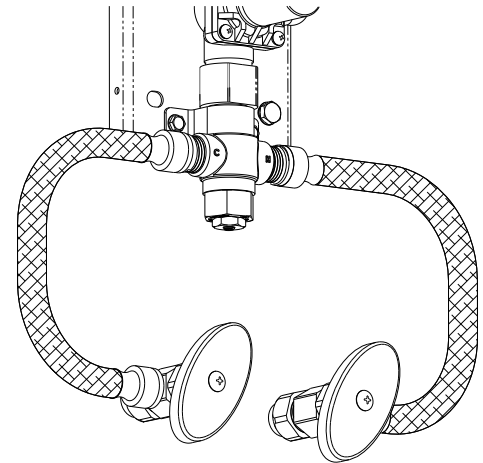

 HINT: Angle stops are recommended and is the responsibility of the installer.

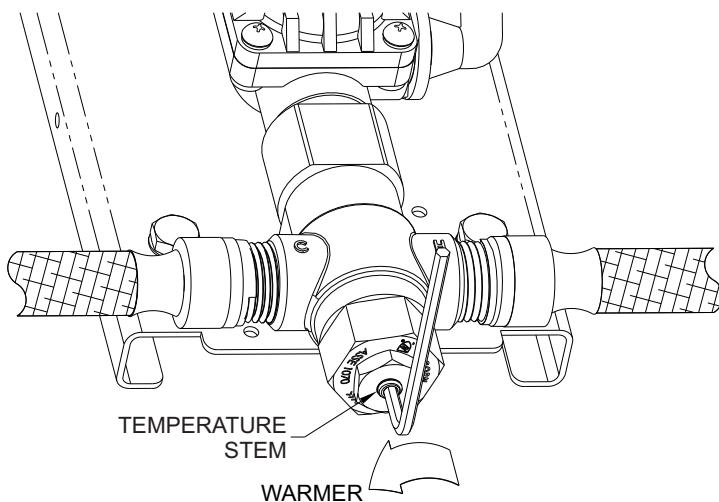

Temperature Adjustment:

- 1) Loosen locknut.
- 2) Turn on fixture and run water for at least 2 minutes. Allow supply temperature to stabilize.
- 3) Turn temperature stem counter-clockwise for hotter or clockwise for colder outlet temperature.
- 4) Tighten locknut to prevent accidental or unauthorized temperature adjustment.
- 5) Re-check outlet temperature.



SENSOR OPERATION & CONNECTIONS

-SO Sensor Operation Range Adjustment

1. Make sure power supply is disconnected from sensor and make short circuit on red wires. See DETAIL A.
2. Connect power supply to sensor. Red light should be flashing.
3. Move hand in front of sensor to distance of 2" to 4" within 5 seconds and wait until red light flashes quickly.
4. Move hand to desired sensing distance. See DETAIL B.
5. Hold hand at desired sensing distance until red light stops flashing and solenoid activates. See DETAIL C.

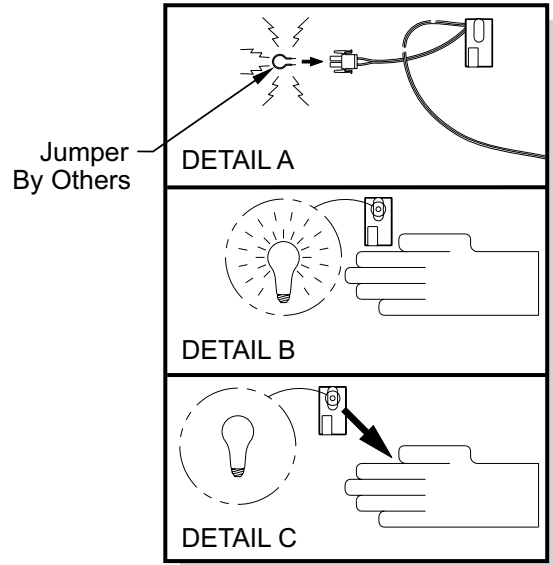

-SO Sensor Operation or -PPZ Programmable Piezo Pushbutton

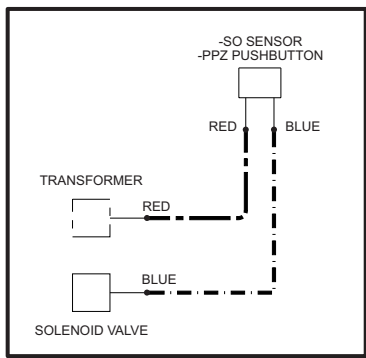
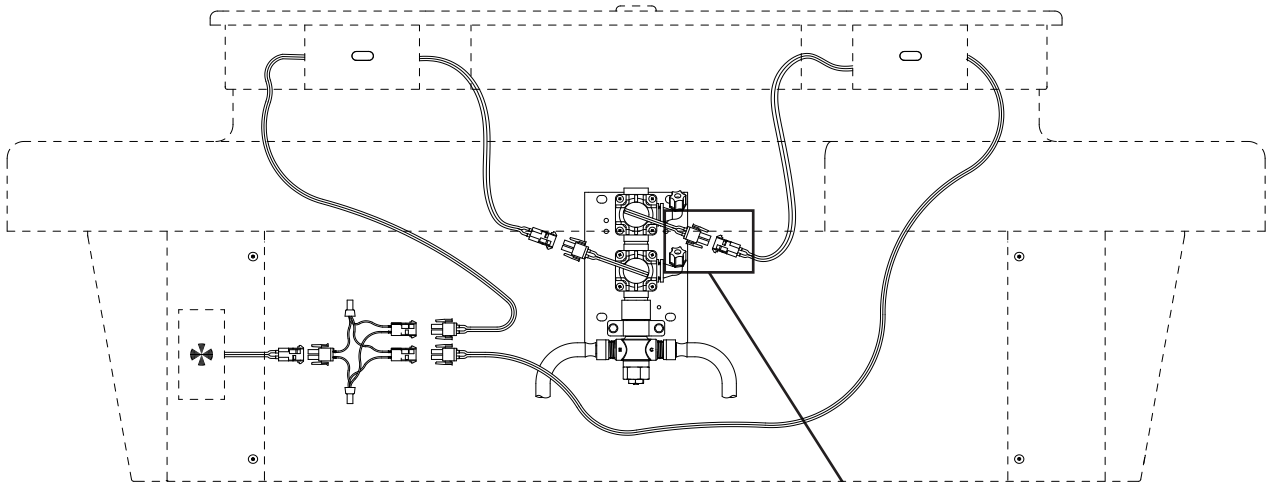

IMPORTANT
Transformer must be plugged into a GFI protected circuit. Fixture must be earth grounded per N.E.C. or applicable codes.

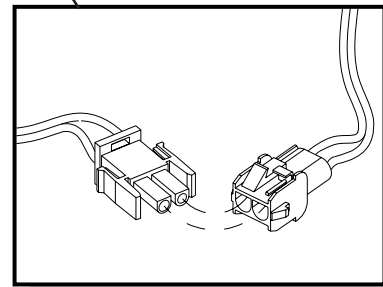



Please visit www.acorneng.com for most current specifications.

MERIDIAN 3792

SENSOR OPERATION & CONNECTIONS -BATTERY OP

-SO-BAT

Sensor Operation Battery Powered

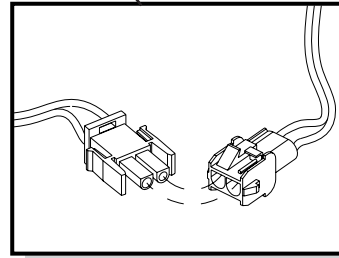
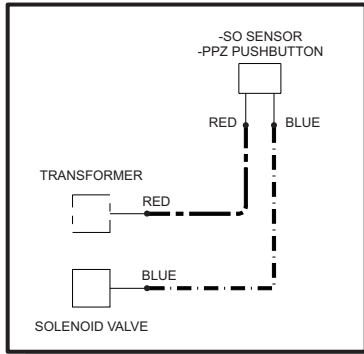
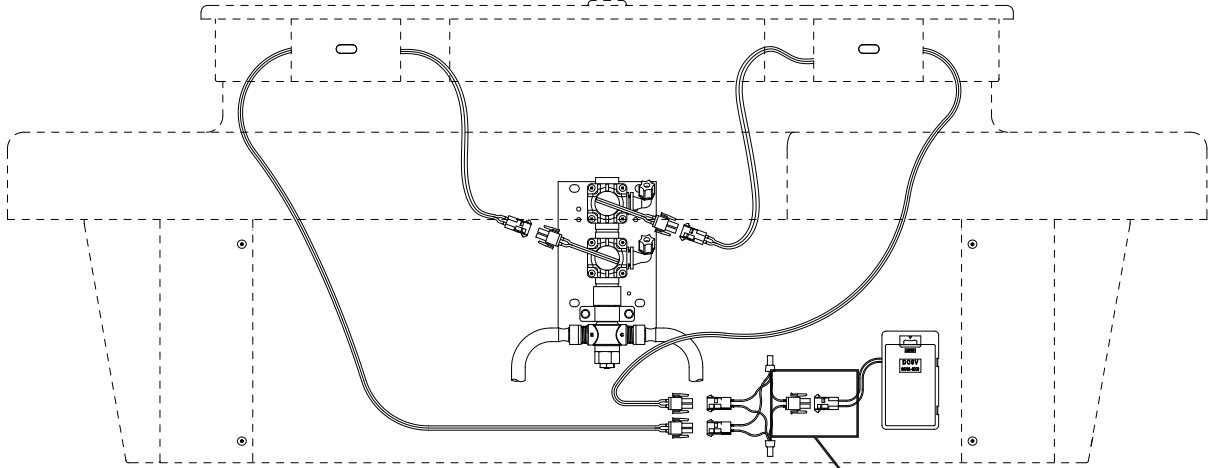

Acorn does not provide batteries for -BAT units. Each Pack requires (6) AA batteries.

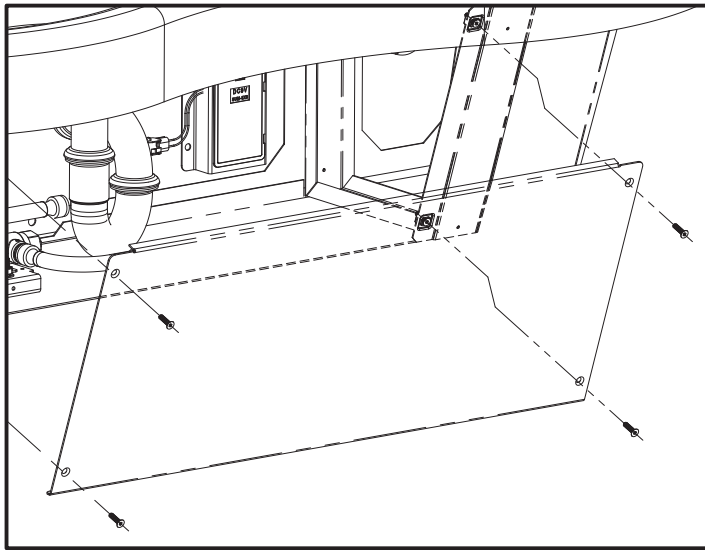

To service or install batteries remove access panel by removing (4) 10-32 x 3/4" screws from front of fixture using allen head bit provided (socket & driver by others). Replace access panel when finished.



Please visit www.acorneng.com for most current specifications.

HAND OPERATION & CONNECTIONS

-H Hand Operated

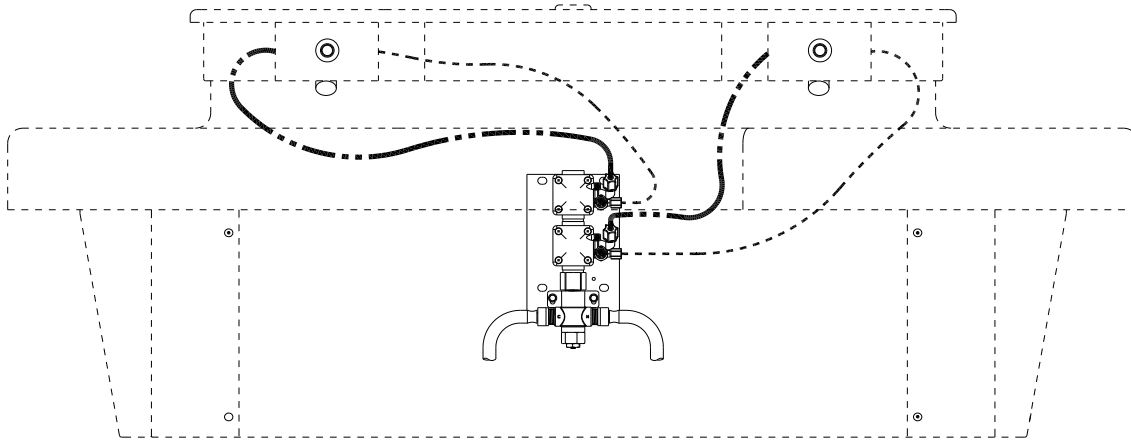

----- 1/8" O.D. AIR TUBE
- - - - - 1/4" O.D. WATER LINE

Ferrule Nut

Timing Screw
To adjust timing,
turn timing screw.

! IMPORTANT
Do not over tighten ferrule nuts.

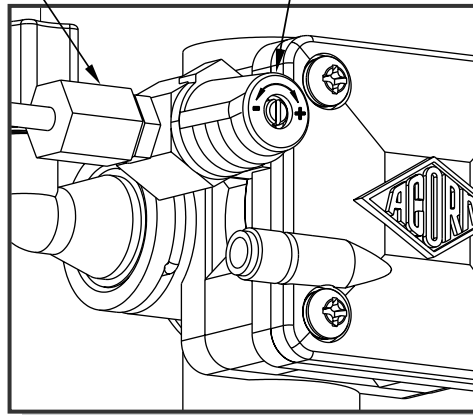

Turn timing screw clockwise to increase timing.

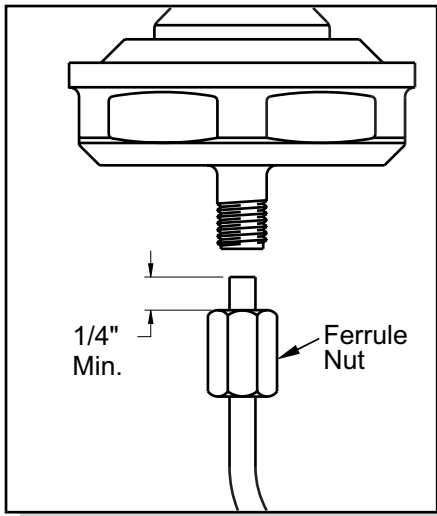

! IMPORTANT
Leave a minimum 1/4" of polyethylene tubing through the Ferrule Nut on the pushbutton assembly. This is necessary to ensure proper tubing connection.



ACCESS PANEL INSTALLATION

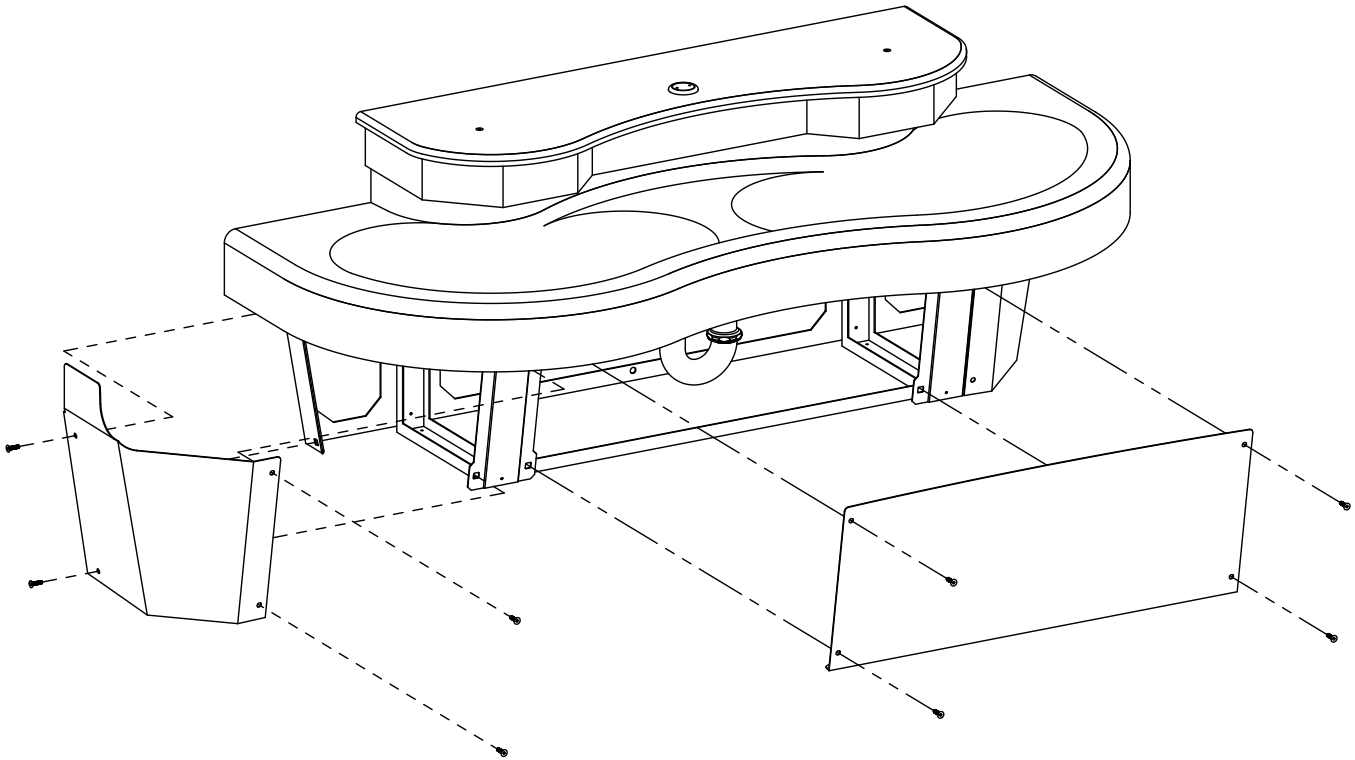

Install front and side access panels using 10-32 x 3/4" center reject hex head screws provided.



Please visit www.acorneng.com for most current specifications.

-DV- SOAP OPTION RETRO-FIT & INSTALLATION

!WARNING Some soaps contain corrosive additives that can cause rust in soap dispensers. Acorn Engineering Company recommends user/ maintenance personnel review MSDS reports of soap and possible corrosive additives noted.

Do not exceed the capacity of the soap tank. Overfilling may result in spilling and pooling of soap solution within the sprayhead enclosure and outside the soap tank.

1 Remove top cover from unit. To remove cover, use Allen head bit provided and unscrew 10-32 x 3/4" long vandal resistant fasteners shown. Hex bit driver is installer provided.

2 Remove Corterra plug from top cover and soap access plug from bottom of sprayhead enclosure.

3 Position and install soap tank in sprayhead enclosure as shown and install soap dispenser by aligning dispenser with drain adapter and fixing with set screws as shown

4 Install soap filler assembly to top cover and replace.

5 Fill soap tank by removing filler cap and pouring soap directly into tank. Do NOT overfill.

Remove Corterra Plug

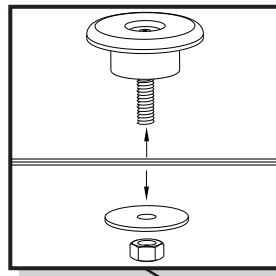

Install Soap Filler

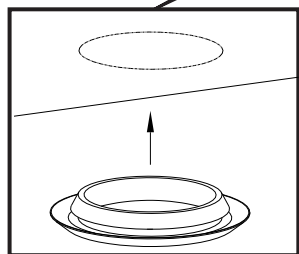
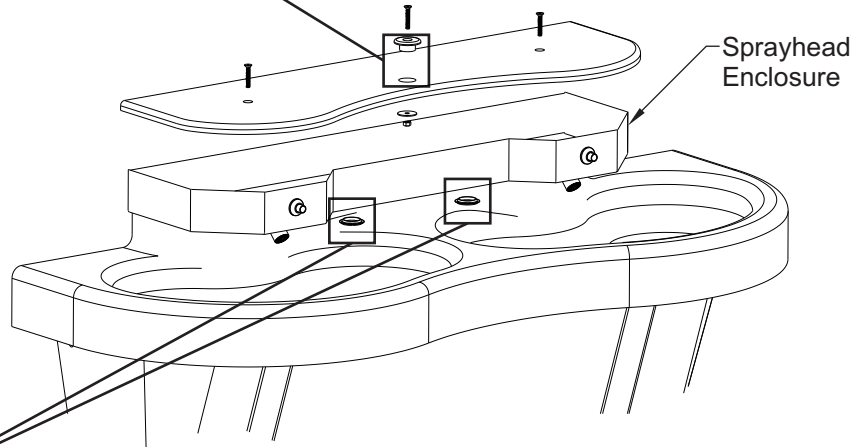
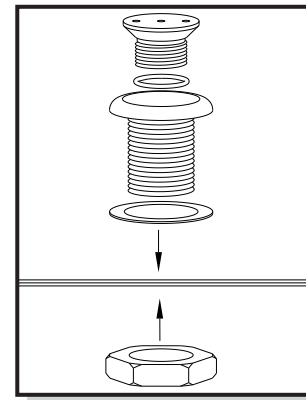

Remove Access Plug

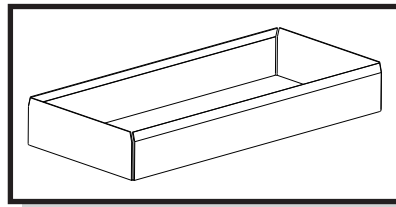

Install Soap Tank

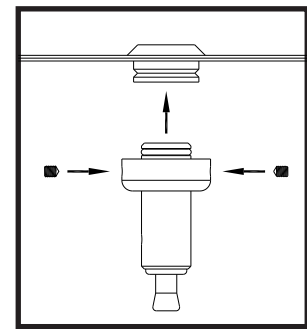

Install Soap Dispenser



NOTE: Soap Tank Capacity = 1 Gallon



Please visit www.acorneng.com for most current specifications.

Optional -KP Kick Plate Rough-Ins

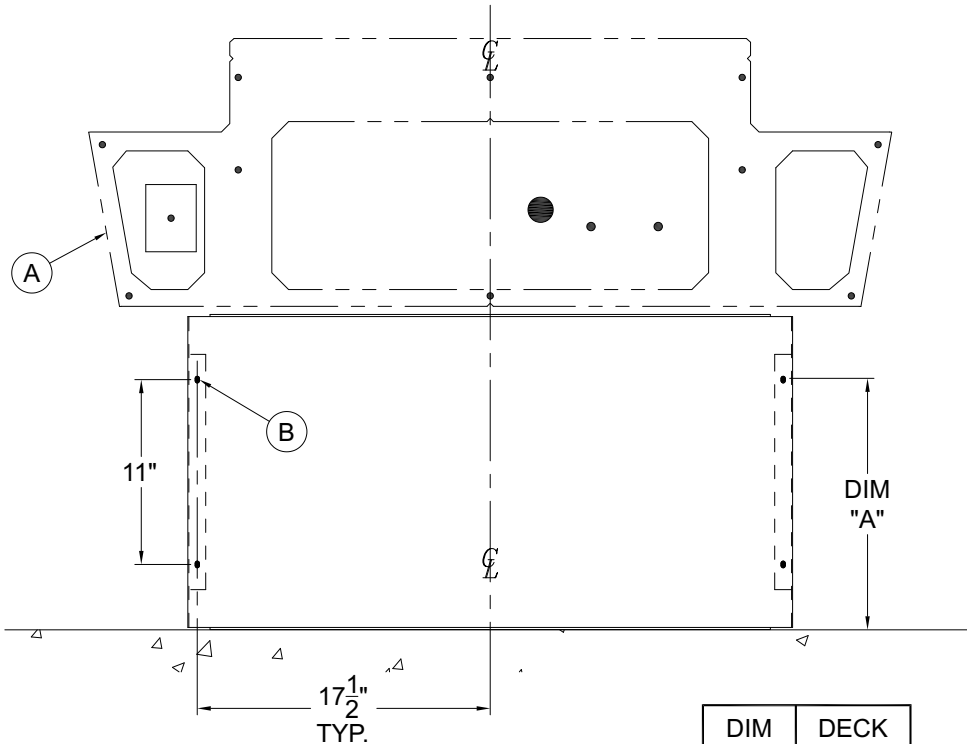

- (A) Sink Mounting Frame, Shown For Reference.
- (B) Ø1/4" x 3/8" Long Slots For Installer Provided Wall Anchors And Anchoring Hardware.

DIM "A"	DECK HEIGHT
15"	34"
14-1/2"	33"
13-1/2"	31"

Optional -KP Kick Plate Installation

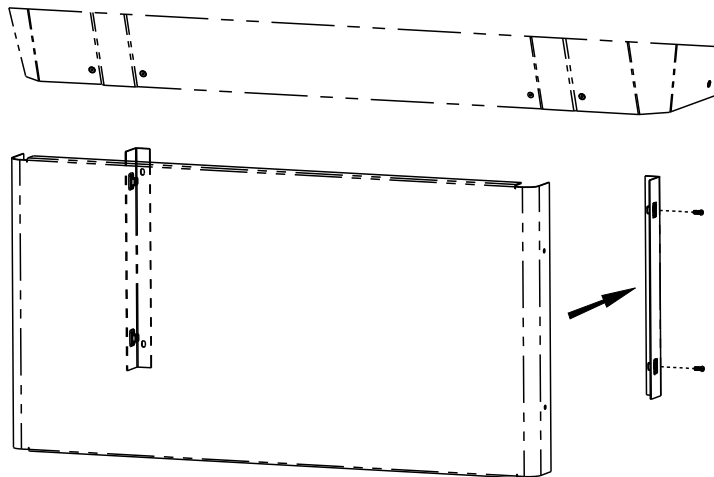



Programable Piezo Pushbutton Programming Instructions (Flow Time Adjustment)

The Button is factory set an 8 sec. timing cycle, if an 8 sec. cycle is adequate, then **no** programming adjustment is required.



NOTE: Read the entire document before trying to program the piezo pushbutton.

THE TIME SETTINGS PROGRAM USES 3 DIFFERENT TIMING MODES:

- **1 second timing mode:** Each push of the button adds 1 second to the total timing cycle.
- **5 second timing mode:** Each push of the button adds 5 seconds to the total timing cycle.
- **20 second timing mode:** Each push of the button adds 20 seconds to the total timing cycle.

To program the piezo pushbutton, you will need to be able to see the back of the piezo pushbutton.

Prevision must be made to access the back of the piezo pushbutton. There is an LED on the back of the piezo pushbutton under a layer of transparent epoxy, used as a programming indicator light.



NOTE: This programming procedure moves along rapidly, there is only about 2 or 3 seconds between programming operations.

In order to start the programming the piezo pushbutton, the button must be powered down. Disconnect the red power cable and wait 20 seconds, then reconnect the red power cable.

As soon as the cable is reconnected the LED will start flashing, it will flash 4 times, then stays on for 3 seconds. During the 3 second period, push the piezo button once, the LED will go out, now you are in the **1 sec timing mode** and each time the button is pushed the LED will flash, adding 1 sec to the total timing cycle.

To move on to the **5 sec timing mode**, pause and wait for the LED to flash 2 times, now you are in the 5 sec timing mode. Each time the button is pushed the LED will flash, adding 5 sec to the total timing cycle.

To move on to the **20 sec timing mode**, pause and wait for the LED to flash 3 times, now you are in the 20 sec timing mode and each time the button is pushed the LED will flash, adding 20 sec to the total timing cycle. After programing is complete, pause and wait for the LED to flash 4 times and then 5 times, which completes the programming.

- When a **timing mode is not required** then **do not** push the button and wait for the next timing mode.
- Each timing mode (1 sec, 5 sec or 20 sec timing mode) can be sequenced up to 100 times, that is the number of times, the button can be pushed, to increase the total timing cycle in each timing mode.



Programmable Piezo Pushbutton Programming Instructions (Flow Time Adjustment)

WORKSHEET

(FILL IN ALL BOXES, WHICH WILL SIMPLIFY THE PROGRAMMING PROCEDURE)

Fill in all the Boxes below
↓ ↓

PROGRAMING STEPS:

- Power down piezo button for 10 seconds.
- Reconnect power.
- LED flashes, then stay on.
- While the LED is steady on, push button.
- LED turns off.

Determine the number of seconds per timing cycle

1 Push = 1 Second
 x 1 = sec



- You are in the 1 sec timing mode, immediately push the button, 1 push equals 1 sec added to the total timing cycle.
- Pause and wait for the LED to flash 2 times.

ADD ↑↓

1 Push = 5 Seconds
 x 5 = sec



- You are in the 5 sec timing mode, immediately push the button, 1 push equals 5 sec added to the total timing cycle.
- Pause and wait for the LED to flash 3 times.

ADD ↑↓

1 Push = 20 Seconds
 x 20 = sec



- You are in the 20 sec timing mode, immediately push the button, 1 push equals 20 sec added to the total timing cycle.

EQUALS ↓

Total timing cycle equals
 seconds



INSTALLATION, OPERATIONS & MAINTENANCE MANUAL

Please visit www.acorneng.com
for most current specifications.

MERIDIAN 3792

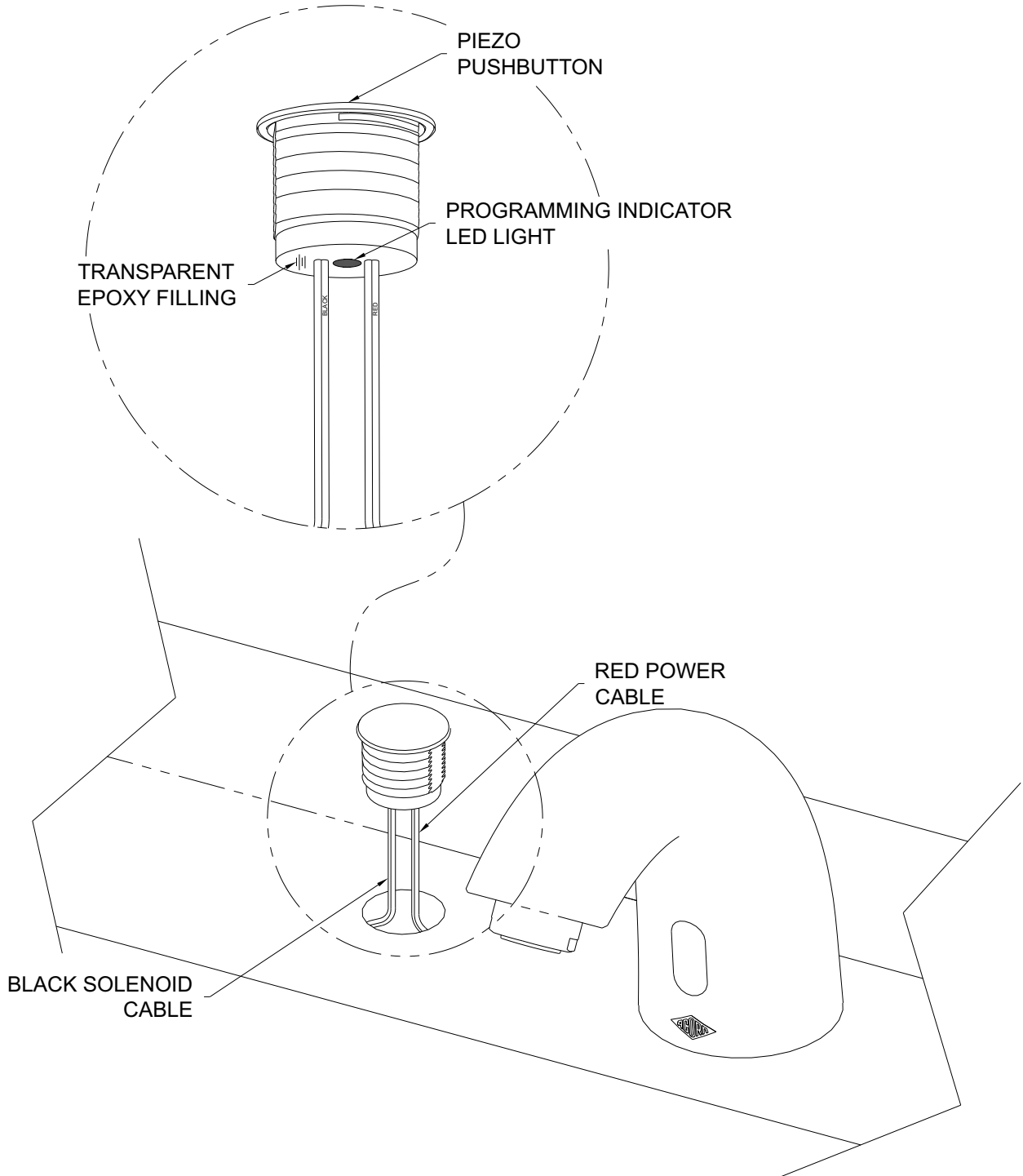





INSTALLATION, OPERATIONS & MAINTENANCE MANUAL

Please visit www.acorneng.com for most current specifications.

MERIDIAN 3792

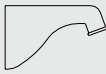
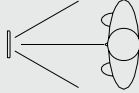
TROUBLE SHOOTING FOR 9 VOLT DC SENSOR OPERATED VALVES

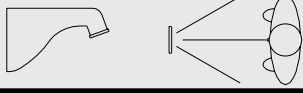
Normal Valve Function: 9 Volt DC sensor operated valve has flow time of 90 seconds maximum. To reactivate, the user must move out of and return to the sensing area.		
CONDITION: WATER DOES NOT FLOW  		
<i>Indicators</i>	<i>Probable Cause</i>	<i>Solution</i>
Sensor flashes continuously every 2 seconds when hands are within range.	Low battery warning	Replace battery
Sensor does not flash when the user's hands are within range.	Circuit breaker tripped.	Reset circuit breaker
	Battery completely used up.	Replace battery
	Defective 9V DC transformer	Replace transformer.
	Transformer polarity crossed	Replace transformer (sensor may be damaged and need replacement).
	Unit is in "Security Mode" after 90 seconds of constant detection.	Remove sources of detection and wait 30 seconds before checking.
	Range is too short.	Increase range.
	Range is too long.	Decrease range and wait 30 seconds.
	Sensor is picking up a highly reflective surface.	Eliminate cause of reflection and wait 30 seconds before checking.
Sensor flashes once when user's hands are within range.	Stops or water main closed.	Open stops or water main.
	Bad sensor to solenoid connection.	Ensure wires make proper contact.
	Debris or scale in solenoid assembly.	Remove solenoid, pull out plunger and spring, and clean with scale remover solution or pressurized air.
	Debris or scale in diaphragm.	Remove diaphragm and clean
	Debris or scale in strainer.	Remove strainer and clean.
CONDITION: FALSE TRIGGERING; WATER FLOWS CONTINUOUSLY 		
<i>Indicators</i>	<i>Probable Cause</i>	<i>Solution</i>
Sensor flashes when user's hands are within range.	Debris or scale in diaphragm	Remove diaphragm and clean.
	Diaphragm is defective or torn.	Replace diaphragm.
Sensor does not flash when users hands are within range.	Sensor is dirty or covered.	Clean or uncover sensor and wait 30 seconds.
	Range too long or highly reflective surface, sunlight, bright lights etc. are triggering sensor.	Decrease range and wait 30 seconds. Eliminate cause of reflection or correct lighting problem.
CONDITION: WATER FLOWS CONTINUOUSLY BUT STOPS WHEN HANDS ARE WITHIN RANGE  		
<i>Indicators</i>	<i>Probable Cause</i>	<i>Solution</i>
Water runs continuously when sensor not activated. Sensor flashes when hands are within range and water shuts off.	Solenoid polarity crossed.	Disconnect solenoid and reverse polarity.



TROUBLE SHOOTING FOR OPTIONAL PUSHBUTTON OPERATED VALVES

Normal Valve Function: Hand pushbutton operated valve has an adjustable flow time from 5 to 60 seconds.	
CONDITION: WATER DOES NOT FLOW	
Probable Cause	Solution
Water main closed.	Open water main.
Checkstops closed.	Open checkstops.
Debris or scale in checkstop strainer	Remove checkstop strainer and clean.
Air leaks from 1/8" O.D. tubing or fittings.	Replace damaged tubing or fitting.
Pushbutton air diaphragm leaks.	Replace pushbutton air diaphragm.
Servomotor diaphragm center hole is blocked.	Remove blockage.
Servomotor upper diaphragm is damaged.	Replace servomotor upper diaphragm.
Low or no water pressure at supplies.	Increase water pressure to 30 PSI minimum.
CONDITION: WATER DRIPS, WON'T SHUT OFF	
Probable Cause	Solution
Servomotor diaphragm offset hole is blocked.	Remove blockage.
Servomotor seat is damage	Replace servomotor seat.
Servomotor plate or diaphragm is obstructed.	Remove cause of obstruction.
Servomotor timer assembly is damaged.	Replace servomotor timer assembly.
CONDITION: REDUCED WATER FLOW	
Probable Cause	Solution
Valve riser tubing is crimped.	Straighten valve riser tubing.
Debris or scale in checkstop strainer	Remove checkstop strainer and clean.
Blockage in valve flow control.	Remove blockage.
Low water pressure at supplies.	Increase water pressure to 30 PSI minimum.
Lime deposits in hot water pipes.	Remove lime deposits with appropriate cleaning solution.
CONDITION: PREMATURE WATER SHUT OFF	
Probable Cause	Solution
Air leaks from 1/8" O.D. tubing or fittings.	Replace damaged tubing or fitting.
Pushbutton air diaphragm leaks.	Replace pushbutton air diaphragm.



CARE, CLEANING, AND REPAIR OF CORTERRA SOLID SURFACE

CORTERRA SOLID SURFACE

Acorn's densified solid surface material is composed of recycled solid-surface polymer resin, aluminum trihydrate and fillers. It is resistant to stains, impact and burns and complies with ANSI Z124.3. It is attractive, durable and easy to maintain.

ROUTINE CLEANING

Corterra should be kept clean at all times. If maintained, Corterra surfaces will retain their new, clean appearance indefinitely. Wash with a non-abrasive all purpose cleaner and water, then rinse. Wipe dry. (Never use cleaners with strong chemicals such as toilet bowl cleaners, rust removers, ceramic cook top cleaners, laquer thinners or oven cleaners). To remove persistent stains use a Scotch Brite pad and an abrasive cleaner or a solution of household bleach and water (1 part water to 1 part bleach).

REPAIRING SURFACE DAMAGE

Surface damage, such as minor chips, scratches, burn marks and graffiti can be repaired with a fine grit abrasive cleanser, such as a Scotch-Brite pad or fine grit sandpaper. For more serious physical damage caused by vandals, an Acorn Solid Surface Repair Kit is available. Contact the factory for details. Refer to drawing #9927-160-002.

SOAP SYSTEMS

Acorn soap reservoirs and dispensers provide a dependable operation over long term when proper maintenance is performed and the correct soap is being used. The most common problem with soap systems is that the wrong viscosity (thickness) of soap is being used or high acidic pH levels are in the ingredients. Soap thickness can be best explained as no thicker or thinner than normal household liquid dish soap. The pH level of the soap should be 6.5 to 8.5; more acidic soaps will corrode the metal parts and degrade rubber or plastic components.

Soap reservoirs and dispensers should be maintained periodically to clear residue. This should be done in hot water to clean the internal components. The valve should be pumped multiple times to thoroughly clean any residue inside. The reservoir and tubing should also be flushed and cleaned with hot water. In cases of extreme clogs, the dispenser should be disassembled and the parts thoroughly cleaned.

WARNING: Some soap contains corrosive additives that can cause rust on stainless steel surfaces. Acorn recommends user/ maintenance personnel review MSDS reports of soap and possible corrosive additives noted.

CARE AND CLEANING OF STAINLESS STEEL SURFACE

NORMAL CLEANING

Clean weekly or more often, as needed
(especially high polishing surfaces)

RECOMMENDED CLEANING MATERIALS

- Sponge – natural or artificial
- Nylon or other soft-bristle material brush
- Soft cloth (as used on automobile finishes)

RECOMMENDED CLEANING SOLUTIONS

- Hand dishwashing liquid/soft water solution
- Mild soap/soft water solution
- 3M Stainless Steel Cleaner/Polish
- White vinegar/soft water solution (for brightening, removing oil and hard water deposits)
- CLR Brand Cleanser or baking soda/soft water solution (for brightening, removing hard water deposits)
- Club soda and sponge

FOR HIGH POLISH STAINLESS STEEL

Note: High polish stainless steel surfaces should never come into contact with any abrasive cleaning brush, cloth or cleaning agent.

To remove smudges and fingerprints:

Wipe surfaces with a quality Stainless Steel Cleaner/Polish. Apply using a soft non-abrasive cloth, wipe surfaces with stainless steel cleaner/polish.

To remove rust stains:

Wipe surfaces with CRES (available from Acorn) or equivalent cleaner. Use recommended solutions. Apply using a soft non-abrasive sponge. Rinse surfaces immediately after application. Always follow cleaner product directions provided. Afterwards, using a soft, non-abrasive cloth, wipe surfaces with stainless steel cleaner/polish.

FOR TOUGH PROBLEMS

- CRES Cleaner specifically for rust stains (available from Acorn)
- Tarn-X for general stains
- #7 chrome polish
- Silver polish

To remove stubborn spots or to treat a scratch (Standard Satin Finish Only):

Use of synthetic, abrasive, general-purpose pads such as Scotch Brite is recommended. Apply the stainless steel cleaner/polish to the synthetic, abrasive pads and CAREFULLY rub out spot with cleaner/ polish. Be sure to rub in the direction of the grain! Do not allow steel wool to come in contact with the stainless steel. Steel particles can embed into the stainless steel surface and create rust!

Stainless steel should be kept clean at all times. If maintained, stainless steel surfaces will retain their new, clean, polished appearance indefinitely. To remove water spots or rust spots, stainless steel cleaner/polish on a cloth is recommended.

IF SPOTS ARE STUBBORN OR IF YOU WISH TO TREAT A SCRATCH: synthetic, abrasive, general-purpose pads such as Scotch Brite are recommended. Apply the stainless steel cleaner/polish to the synthetic, abrasive pad and CAREFULLY rub out spot with cleaner/polish. **Be sure to rub in the direction of the grain!** Do not allow steel wool to come in contact with stainless steel. Steel particles can embed into the stainless steel surface and create rust.



Please visit www.acorneng.com
for most current specifications.

COMPONENTS & REPAIR PARTS

Description	Part No.	Diagram
MOUNTING HARDWARE		
10-32 UNF x 3/4" Center Reject Hex Socket Head Screw	0152-006-000	
1/4"-20 UNC x 1" Hex Head Cap Screw	0206-002-000	
1/4"-20 UNC x 1/2" Hex Head Cap Screw	0206-004-000	
1/4" Lock Washer	0337-050-000	
1/4" Flat Washer	0331-005-000	
1/4" Fender Washer	0331-031-000	





INSTALLATION, OPERATIONS & MAINTENANCE MANUAL

Please visit www.acorneng.com
for most current specifications.

MERIDIAN 3792

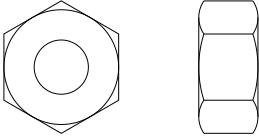
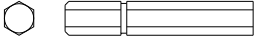
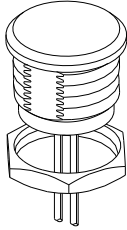
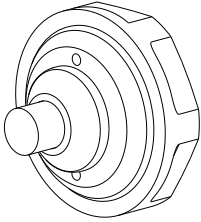
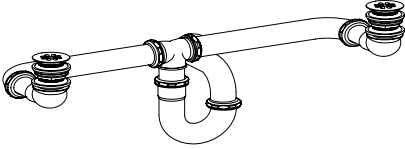
COMPONENTS & REPAIR PARTS

Description	Part No.	Diagram
1/4"-20 Hex Nut	0302-005-000	
Allen Head Bit With Center Reject	0296-025-199	
PUSHBUTTONS		
Blank Piezo Pushbutton	0709-067-001	
Pushbutton Assembly	2566-050-001	
COMBINED WASTE ASSEMBLY		
Waste Assembly	4970-008-001	
Elbow Grid Strainer	4926-062-001	



Please visit www.acorneng.com for most current specifications.

COMPONENTS & REPAIR PARTS

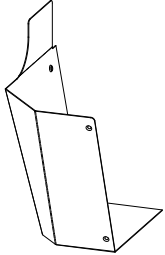
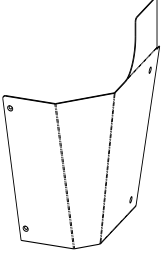
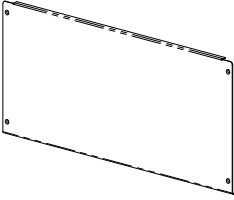
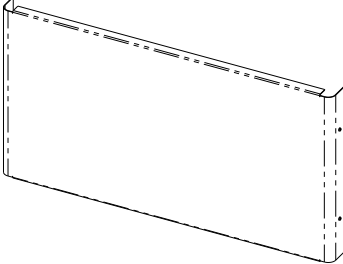
Description	Part No.	Diagram
ENCLOSURES		
Left Hand Cover Plate	6214-052-299	
Right Hand Cover Plate	6214-053-299	
Front Cover Plate	6214-054-199	
Kick Plate Assembly	6214-040-001	



INSTALLATION, OPERATIONS & MAINTENANCE MANUAL

Please visit www.acorneng.com
for most current specifications.

MERIDIAN 3792

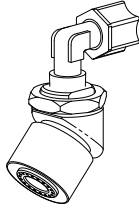
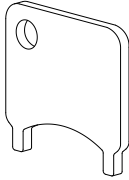
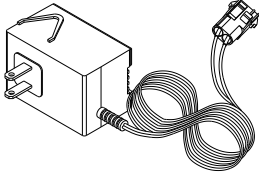
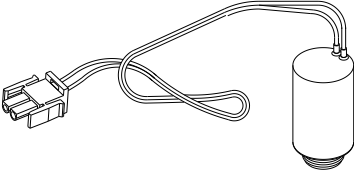
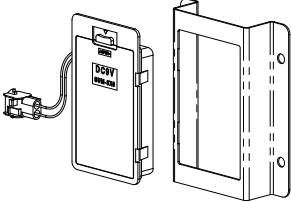
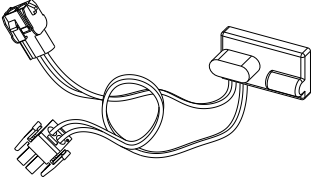

COMPONENTS & REPAIR PARTS

Description	Part No.	Diagram
SPOUT ASSEMBLIES		
Nozzle Assembly	6214-005-001	
Spanner Key For Spout Aerator And Soap Filler	2998-055-199	
ELECTRONIC HARDWARE		
9 VDC Plug-In Transformer	0711-410-001	
9 VDC Solenoid	2563-326-001	
9 VDC Battery-Pak Assy (6 AA Batteries Not Included)	0710-358-001	
Battery-Pak Mounting Bracket	6155-013-199	
Sensor Assembly	2562-373-001	

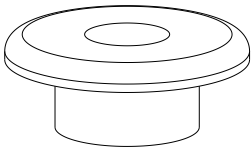

Please visit www.acorneng.com
for most current specifications.

COMPONENTS & REPAIR PARTS

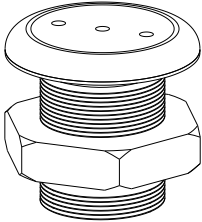
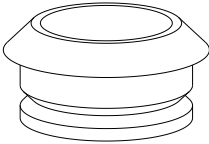
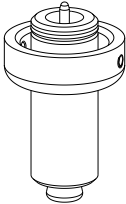
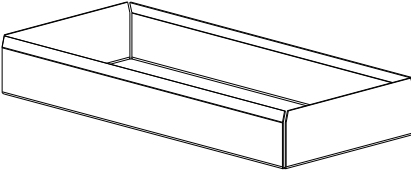
Description	Part No.	Diagram
DV- SOAP OPTION		
Corterra Plug Contact factory for color selection	6214-109-101	
Access Plug	6213-129-000	
Soap Filler Assembly	6214-004-001	
Soap Tank Drain Adapter	6214-012-199	
Soap Dispenser Assembly	6214-009-001	
Soap Tank - 1 Gal Capacity	6214-006-001	



INSTALLATION, OPERATIONS & MAINTENANCE MANUAL

Please visit www.acorneng.com
for most current specifications.

MERIDIAN 3792

COMPONENTS & REPAIR PARTS

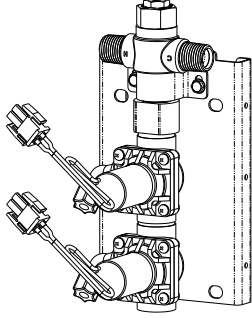
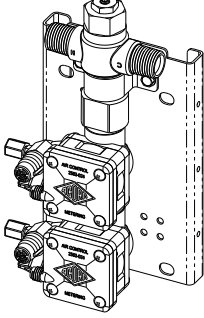
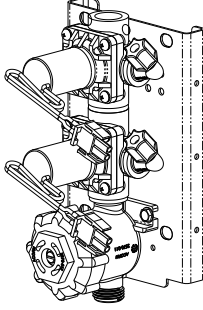
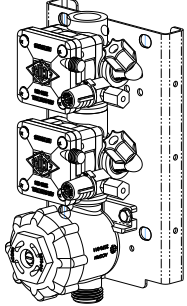
Description	Part No.	Diagram
VALVE		
T/P 2-Station, 9VDC Solenoid, ASSE 1070, Mixing Valve Assembly	2598-232-001	
Optional T/P 2-Station, Hand Operated, ASSE 1070, Mixing Valve Assembly	2598-202-001	
Optional 2-Station, 9VDC Solenoid, Single Temp Valve Assembly	2598-332-001	
Optional 2-Station, Hand Operated, Single Temp, Metering Valve Assembly	2598-302-001	



INSTALLATION, OPERATIONS & MAINTENANCE MANUAL

Please visit www.acorneng.com
for most current specifications.

MERIDIAN 3792



ACORN ENGINEERING COMPANY

Manufacturers of Engineered Plumbing Products

MAIL ADDRESS

P.O. BOX 3527
CITY OF INDUSTRY, CA 91744 U.S.A.

PHYSICAL ADDRESS

15125 PROCTOR AVENUE
CITY OF INDUSTRY, CA 91746 U.S.A.

TOLL FREE 800-488-8999 • **LOCAL** 626-336-4561
FAX 626-961-2200 • **WEB** www.acorneng.com

WARRANTY INFORMATION

Acorn warrants that all of its products are guaranteed against defective material or poor workmanship for a period of one year from date of shipment. Acorn's liability under this warranty shall be discharged by replacing without charge F.O.B. City of Industry, California, any goods, or part thereof, which appears to the company upon inspection to be of defective material or not of first class workmanship, provided that claim is made in writing to the company within reasonable period after receipt of the product. Where claims for defects are made, the defective part or parts shall be delivered to the company, prepaid, at City of Industry, California for inspection. Acorn will not be liable for the cost of repairs, alterations or replacement, or for any expense connected therewith made by the owner or his agents, except upon written authority from the Acorn City of Industry office. Acorn will not be liable for any damages caused by defective materials or poor workmanship, except for replacements, as above provided. Contact local Acorn Representative for complete terms and conditions.